

BUILDERS' HARDWARE

from the

GROUND UP

By W. N. Thomas

**The A B C of Builders' Hardware
Written Specially for Retailers,
Wholesalers, and Their Salesmen**

Reprinted from HARDWARE AGE

Foreword

“BUILDERS’ Hardware From The Ground Up” was written at the earnest solicitation of the Editorial Staff of Hardware Age, who recognized the urgent need of some medium that would impart to hardware merchants, jobbers and salesmen, a practical working knowledge of a truly fundamental hardware line.

To the average hardware merchant “Builders’ Hardware” stands for something deep and mysterious—an intricate problem to be solved only by the brilliant minds of a favored few.

The hardware dealer is willing to concede that Builders’ Hardware, properly handled, is one of the most profitable lines a retail merchant can handle. He realizes that it is a foundation or feeder line, which opens up opportunities for sales in every department of his store. However, he shies at the words “properly handled,” confessing his ignorance of what is to him more or less a mystery.

And yet—Builders’ Hardware is in no sense the abnormally mysterious and difficult line it has been pictured. True, it requires a certain amount of knowledge to market it successfully, and that knowledge has, in the past, been somewhat difficult to obtain. Individual manufacturers have gone into details about their own particular items, but the subject as a whole has been neglected.

Some merchants who went ahead on the theory that experience is the only teacher, have found that experience is both slow and expensive, and handicapped by poorly selected stocks or inadequate knowledge have

either given up Builders’ Hardware as a bad job or allowed it to drift as an unprofitable side issue.

Be that as it may, the handling of Builders’ Hardware is a simple problem once you know how, as the writer of this book clearly demonstrates.

“Builders’ Hardware From The Ground Up” is a practical, A B C text book, which robs builders’ hardware of its mystery and presents it for what it really is, a comparatively simple, easily understood and profitable line of hardware.

The author, W. N. Thomas, knows his subject as few in this country know it. He also has the ability to impart his knowledge to others in a readable and understandable way. He has been a builders’ hardware salesman, a contract man and for years his function was to figure the *Big Jobs* of his retail customers; to read the blue prints, select the hardware and satisfy the customer.

There is nothing mysterious about Builders’ Hardware so far as Thomas is concerned. If you read what he has written, there will be nothing mysterious about it so far as you are concerned.

In the following pages you will find the solution of those perplexing builders’ hardware problems which have bothered you in the past. Styles, kinds and finishes are fully explained and illustrated: blueprints and specifications are made clear; methods of stocking, displaying and selling are discussed. Nothing is left to the imagination.

“Builders Hardware From The Ground Up” lifts the veil—banishes the mystery and points the way to pleasure and profit.



Editor, Hardware Age.

Builders' Hardware From the Ground Up

By W. N. THOMAS

Table of Contents

	PAGES
CHAPTER I.	
What You Should Know About Locks.....	1
CHAPTER II.	
Knobs, Roses and Escutcheons	11
CHAPTER III.	
Fire Exit Bolts	14
CHAPTER IV.	
Butts and Hinges	16
CHAPTER V.	
The Principal Features of Door Closers	21
CHAPTER VI.	
Bolts and Door Stops	23
CHAPTER VII.	
Window Hardware	26
CHAPTER VIII.	
Hardware for Bath and Toilet Rooms	32
CHAPTER IX.	
Rough Hardware and Contractors' Supplies	34
CHAPTER X.	
Metals, Finishes and Woods.....	36
CHAPTER XI.	
Architecture and Its Relation to Hardware	40
CHAPTER XII.	
Hardware Suited to Period Architecture	43
CHAPTER XIII.	
Colonial Hardware and Architecture	46
CHAPTER XIV.	
Blueprints and Specifications	48
CHAPTER XV.	
Estimating the Quantity of Hardware	51
CHAPTER XVI.	
Selecting Hardware for the House	55
CHAPTER XVII.	
Builders' Hardware from the Sales Angle	57

*Reprinted from and
Copyrighted 1924 by*
HARDWARE AGE
239 West 39th Street
NEW YORK

CHAPTER I.

What You Should Know About Locks

WE are presenting these articles with the idea of being helpful to young men, probably now engaged in the hardware stores of this country, who are desirous of acquiring a working knowledge of builders' hardware. We do not expect to make "builders' hardware men" of them, but we do hope to help them to such an extent that they will be able to make "builders' hardware men" of themselves.

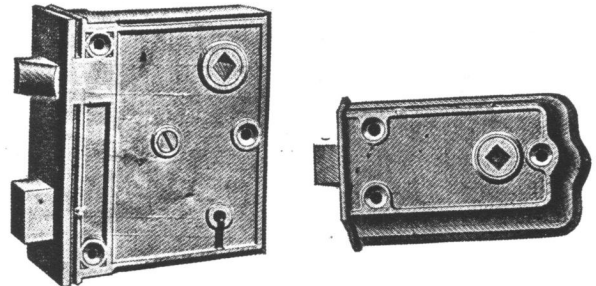
With this thought we have planned a rather elementary beginning, as a foundation on which to build. We will start with the general classification and common uses of the various types of locks.

Locks are used in so many different places and are called upon to do such a variety of things that frequently the distinction between two locks is so slight as to be scarcely noticeable. However, there are a number of well defined classes or groups into which locks can properly be divided and it is from this angle that we will now consider them.

Reference to the accompanying chart (Fig. 1) will assist the reader.

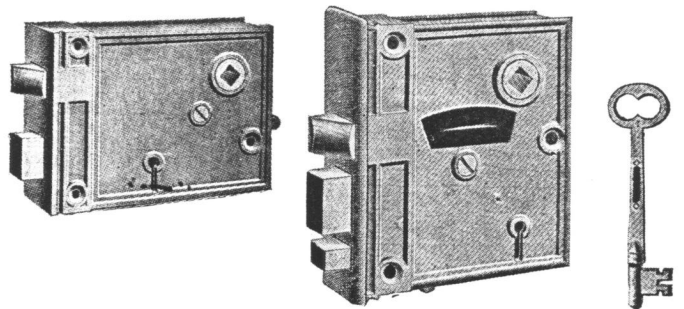
The Various Kinds of Locks

Rim locks, the first general group, are those applied to the outside or rim of the door. Some are Janus-



At left (Fig. 2), Janus-faced rim lock. At right (Fig. 3), single-faced rim lock

faced (Fig. 2); that is, two-faced—named for the Roman God Janus, who, as you know, is shown with two faces—one looking in either direction in order to be ready for any emergency. The Janus or double-faced locks are ready to be applied with either face to the door and in that way are reversible. Others are single-faced (Fig. 3) with only one face suited to be applied to the door, and in locks that cannot be turned bottom side up are not reversible. Rim locks are the oldest type. They have been made in all sorts and descriptions but at the present time are not generally used in this country save only the cheaper kinds. They are still used in Europe, especially in France, where they are made of high quality and finish. In France gold plated rim locks of beautiful design are often used on high grade work. These fine and ornate rim locks are reproduced in this country for use where the architectural requirements are

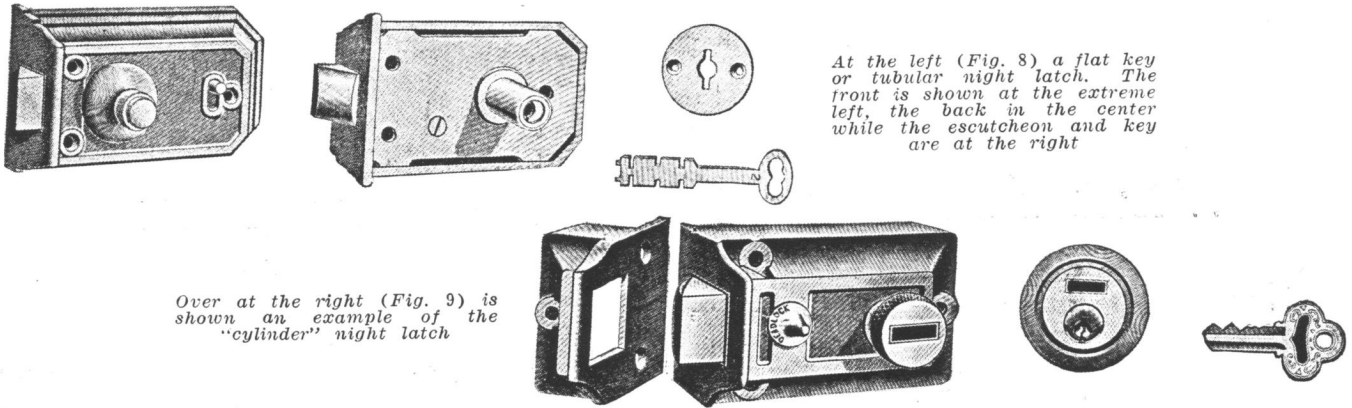


At left (Fig. 4) is an example of the horizontal rim lock

At right is an upright rim lock (Fig. 5) equipped with key bolt. Key is shown at extreme right

LOCKS.	RIM.....	KNOB LOCKS.....	Upright Horizontal Latch Bolt only Latch Bolt	
		KNOB LATCHES...	and Thumb Bolt Bit Key Flat Key or Tubular	
		NIGHT LATCHES...	Cylinder Drawback with Dead Bolt Flat Key and Cylinder	
		DEAD LOCKS.....	Bit Key Folding Key and Flat Key Store Door Locks	
		SLIDING DOOR...		
		KNOB LATCHES...	{ One Bolt Two Bolt Three Bolt	
		NIGHT LATCHES...	{ Bit Key and Cylinder	
		DEAD LOCKS...	{ Cylinder Thumb Knob Turnbuckles Bit Key Narrow Stile or French Window 1" to 2"	
		MORTISE.	KNOB LOCKS.....	Regular Stile... 3 1/4"
				or Backset... 4"
LOCKS.	MORTISE.	2 1/2" to 2 3/4"	4 1/4"	
		5"	4 1/2"	
		5 1/2"-6"-8"	5"	
		Hotel Locks		
		Front Door... (Bit Key		
		and		
		Office Locks... (Cylinder		
		Half Mortise		
		SLIDING DOOR...	Mortise	
		STORE DOOR.....	Flat Key Bit Key Cylinder Latches	
"UNIT"				
"MONO"				
LOCKS.	"UNION" LOCKS...	Front Door Locks		
		Vest. Door Latches		
		Office Door Latches		

Fig. 1—The various classes of locks



Over at the right (Fig. 9) is shown an example of the "cylinder" night latch

At the left (Fig. 8) a flat key or tubular night latch. The front is shown at the extreme left, the back in the center while the escutcheon and key are at the right

best carried out by having the hardware conform to the same period of time as the architectural details.

Rim locks are divided into five classes—knob locks, knob latches, night latches, dead locks and sliding door locks.

If you will take from stock locks of the different kinds described in this article and study them in connection with the article it will help in fixing in your mind the points mentioned—take the locks apart and see how they are made.

Knob Locks

Knob locks, so called because they are operated by both a knob and a key, are divided into two classes—upright and horizontal.

Upright rim locks (see Fig. 2) are those having the knob over the keyhole, and their size is designated by the measurement from top to bottom.

Horizontal rim locks (Fig. 4) are those having the long distance across the door and are measured from front to back. In this class the key-hole is between the knob and the edge of the door. Both upright and horizontal types are made in much the same types and have about the same functions. They each have a latch bolt—so called because it latches or springs out after it is drawn in by a turn of the knob. They also have a dead bolt. This has no spring, and therefore is dead, and must be thrown in or out by the key. This is sometimes called a key bolt. In addition to the above two bolts some have a slide or thumb bolt (Fig. 5), which is pushed in or out by the thumb or finger and is operated only from the inside of the door. Some styles also have stops. This is a little slide or lever which pushes into such a position as to stop the knob from turning from either side, so that the latch bolt cannot be turned back while the stop is on.

Knob latches (Fig. 6) form the second class. These have latch bolts but no key bolts; however, some do have the additional slide or thumb bolts.

Night Latches

Night latches fall within the third class—so called because they are most commonly used at night as an additional security to ordinary knob locks or knob latches, and still allow admission to those having the proper key. They have a latch bolt only which is operated from the outside by the key only—but from the inside by a turn or slide knob. They are sometimes improperly called "dead latches." Night latches may be divided into three classes—bit key, flat key or tubular and cylinder.

Bit key night latches (Fig. 7) are those operated by a key having an extension near the end of a long stem. This extension is known as the bit—hence the name "bit key."

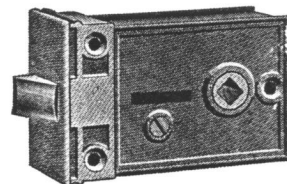
Flat key or tubular night latches (Fig. 8) are those operated by a flat steel key and are made with a tube on the back which projects through the door. In this tube are the tumblers or key obstructions which give the security to the lock.

"Cylinder" night latch, (Fig. 9) are so called because it is fitted with a pin tumbler cylinder which is connected with the lock by machine screws through a hole in the door. These cylinders are made with four or five pin tumblers (according to the grade), and in regular stock have three keys each, while the cheaper form of night latches ordinarily have but two keys. Cylinder night latches are the highest grade and afford the greatest degree of protection. These are made in a number of variations to suit the many requirements. A particular type of cylinder night latch is made for the export trade. It is of the drawback type (Fig. 10), the latch bolt is drawn back on inside by a little handle or tail piece instead of by the knob type. Some have in addition a dead bolt. This is really a form of rim cylinder front door lock.

Dead Locks and Rim Sliding Door Locks

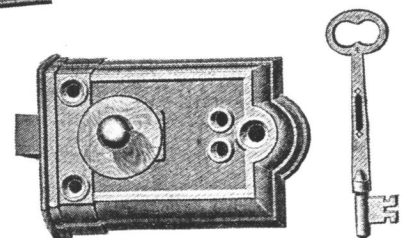
Dead locks (Fig. 11), the fourth class, so called because they have dead bolts, or key bolts only, are divided into three classes—bit key, cylinder and store door or folding key.

Rim sliding door locks, the fifth class, are adapted to use on sliding doors, such as garage and barn doors.

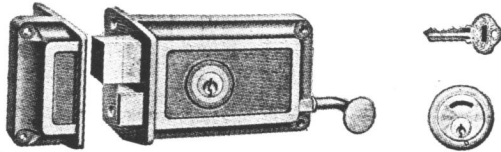


(Fig. 6) Knob latch

(Fig. 7) At the right is seen an example of a bit key night latch



Mortise locks, the second general group, are so called because they are mortised or let into the stile of the door. It may be well to say here that the stiles of a door are the two outside upright pieces. The one on which the lock is put is called the lock-stile, and



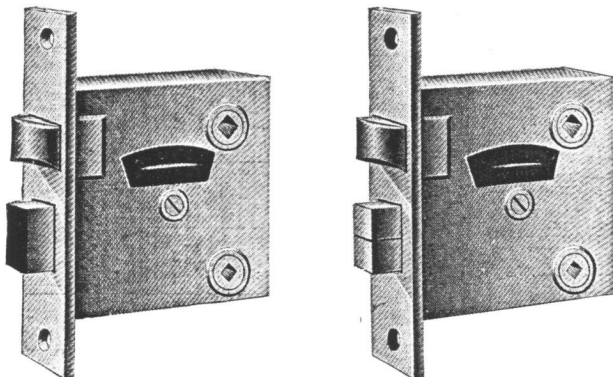
(Fig. 10) Cylinder night latch of drawback type

the one to which the hinges or butts are attached is called the hinge stile. The cross pieces of a door are called the rails—top rail, bottom rail and center or lock rail. Mortise locks are divided into seven classes—knob latches, night latches, dead locks, knob locks, sliding door locks, store door locks and mono unit or union locks.

The mortise lock types or classes, so far as the functions of the locks are concerned, compare very closely with the same type or class of rim locks, but differ mainly in the fact that they are mortised into the door instead of being placed on the outside as rim locks are.

Mortise knob latches are made in three classes. Some are made with the latch bolt only (Fig. 12), others with a latch bolt and one dead bolt, while others have a latch bolt and two dead bolts. The dead bolts are operated by thumb knobs. Those having one dead bolt (Fig. 13) are for use on bathroom and toilet room doors. The thumb knob on the inside of the door being much more convenient than a key because it is always there. Those having two dead bolts (Fig. 14) are intended for doors between two rooms and are called communicating door locks. There is one bolt to operate from either side of the door, so the door cannot be opened unless it is agreeable to the occupant of each room.

Mortise night latches are made both in bit key and cylinder key. There are some variations of the regu-

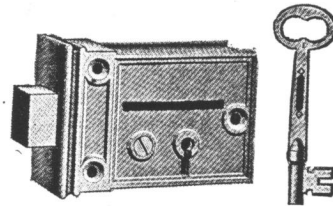


At left (Fig. 13), Mortise knob latch with single dead bolt. At right (Fig. 14), Same style with two dead bolts

lar night latches, made to suit special requirements, usually intended to lock people into a room rather than out of it, and in that respect differ from the night latches. These are principally used in asylums or other institutions.

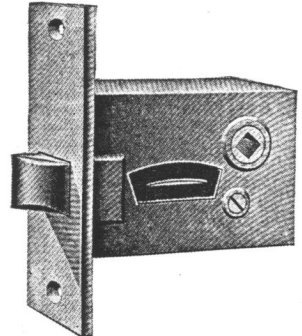
There are four classes of mortise dead locks: Bit key (Fig. 16), cylinder (Fig. 17), dead locks operated by thumb knobs (Fig. 18) and turnbuckles (Fig. 19) the bolts of which are turned up and down, instead of in and out, by a thumb knob, and are intended for casement or French windows, the strike and bolt being made in such a manner as to bind the window tight to the jamb when the bolt is turned down.

Mortise knob locks are divided into four classes: The narrow stile or French window lock (Fig. 20) with a backset (that is, the distance from the face of the lock to the center of the knob and keyhole; narrow stile locks are also called short backset locks) from 1 in. to 2 in. Next is the "regular style" (Fig. 21) the backset of which ranges from 2½ in. to 2¾ in. These are made in several sizes, the size being determined by measuring the case from top to bottom, suiting them for the various grades of buildings on which they are to be used. They are intended for passage doors where the function of a knob lock gives the required convenience and security.



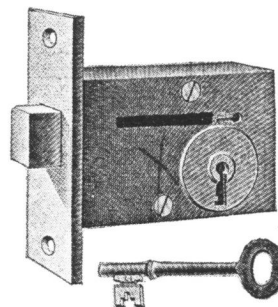
(Fig. 11) Example of the dead lock type

(Fig. 12) Mortise knob latch made with single latch bolt only

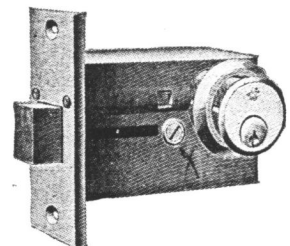


The third class of mortise knob locks is hotel locks—so called because they are especially adapted to the peculiar requirements of hotel work (will take up this later) and embody a large variety—corridor (Fig. 22), single and twin communicating (Fig. 23) with keys, bathroom (Fig. 24).

The fourth subdivision of mortise knob locks are the front door and office door locks (Fig. 25), so



(Fig. 16) bit key mortise dead lock



(Fig. 17) cylinder mortise dead lock

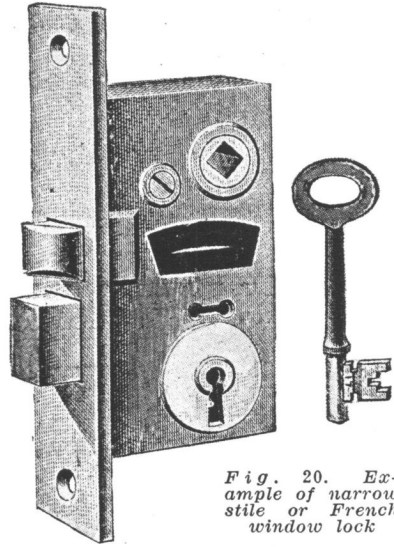
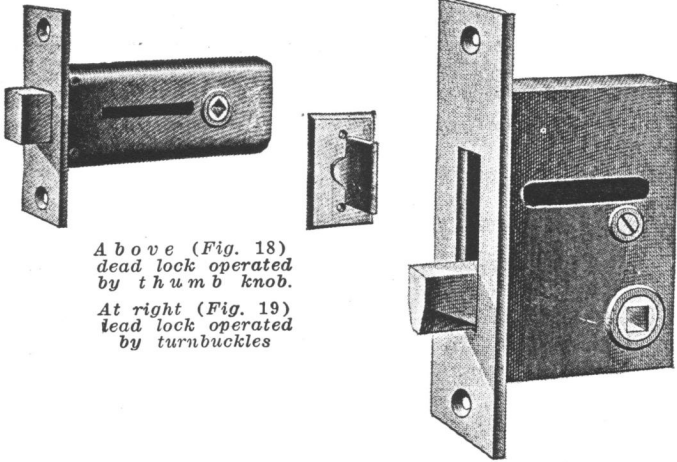


Fig. 20. Example of narrow stile or French window lock

called because they are used for entrance doors to dwelling houses, apartments and offices. For good buildings these should always be of the cylinder type. Bit key, front door locks are intended only for cheaper dwellings.

In the fifth class of mortise locks are found the sliding door locks, so called because they are used on sliding doors. They are made mortise and half mortise (Fig. 26), i. e., set into the door so the case is flush with one side of the door. The half mortise kind are used mostly on elevator sliding doors. Mortise sliding door locks are made bit key and cylinder key.

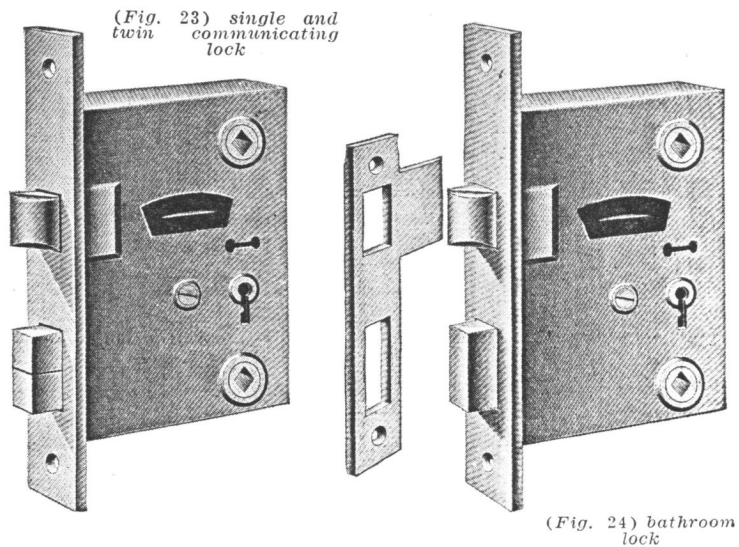
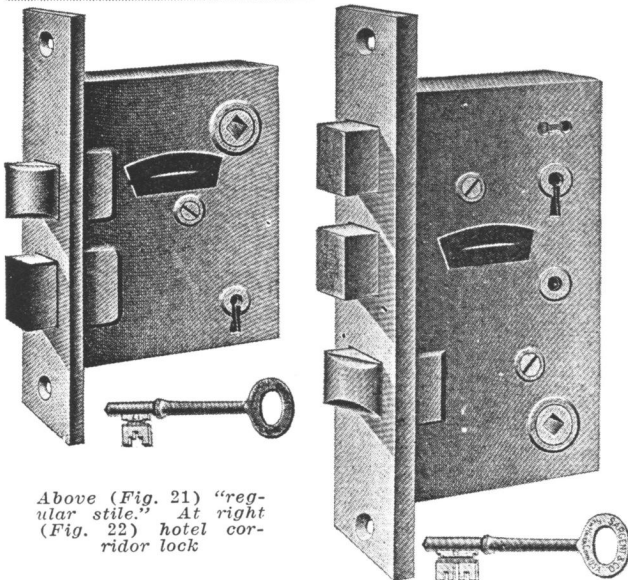
Store door locks (Fig. 27) comprise the sixth class of mortise locks. These are used particularly on store entrance doors. The latch bolt is drawn back by pressing on a thumb piece instead of turning a knob. They are made with flat keys and cylinder keys.

The seventh class of mortise locks is known by several different trade names, such as "Mono," "Unit" and "Union" (Fig. 28). The lock, knobs and escutcheon plates are assembled at the factory into a complete set that is slipped in a simple mortise cut into the door and is adjusted to the thickness of the door by the tightening of a couple of machine screws. The particular advantage claimed for this type of lock over the regular mortise sort is that the operating parts all retain their proper relative position one to another

as they were made at the factory, and therefore operate more satisfactorily than the sets assembled by the carpenter on the door. These are usually made cylinder type with the key operating in the outside knob. They are especially suitable for entrance doors to offices and apartments in high-grade buildings.

In order to give a short explanation of the several principal parts of locks, as shown in Fig. 29, it may assist the beginner in fixing in his mind the common usage of these names.

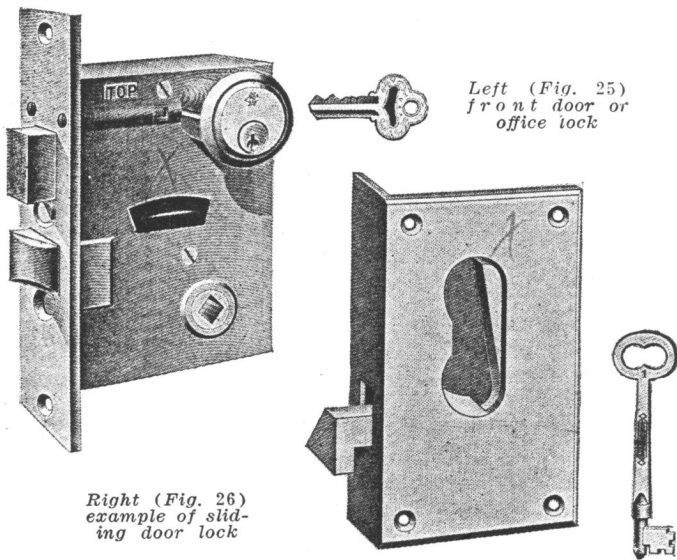
The face of a mortise lock is that part which shows on the edge of the door (Fig. 30). A "flat face" is one that stands at right angle to the body or case of the lock. Most of the smaller locks intended for thin doors have fairly narrow faces and are flat-faced. For thicker doors the lock faces are wider and usually are beveled, that is, they stand slightly off of right angle to the case so as to fit the face of the door. The bevel is on the edge of the door that closes against the stop. Doors, 1 3/4 in. and over in thickness are usually beveled at the rate of 1/8 in. to 2 in. This is done to permit the doors being opened and closed easily when closely fitted. "Bevel-faced" locks (Fig. 31) are handed—that is, right hand or left hand—and are



not generally reversible. However, some manufacturers make locks that have the face put on the case in such manner as to allow it to be adjusted on the job either beveled right hand, beveled left hand, or flat-face. This is a great convenience to the hardware man.

Pairs of doors (double doors) frequently have the lock faces rabbeted (the standard rabbet is 1/2 in.) and require locks with rabbeted faces; these are not reversible.

Double-acting doors—that is, doors that are hung on spring hinges and open in either direction—usually have the edge of the lock stile rounded so that the door will not strike in closing from either direction. These require locks with rounded faces to fit the edge of the door; and they should be dead locks, as latch bolts do not work from either side.



Right (Fig. 26) example of sliding door lock

Left (Fig. 25) front door or office lock

FRONT OR FACE.	{ Flat Beveled Adjustable Rabbeted for Pairs of Doors Rounded for Double Acting Doors Selvedge
STRIKES	{ Rim Rim—Reverse Bevel Mortise Mortise Box Mortise Protected
BOLTS	{ Latch—(by Knob) Dead by Key on Thumb Knob Slide or Thumb Bolt Auxiliary or Guard
SPRINGS	{ Flat or Stiff Soft Layer Easy Compression Easy
HUBS	{ Solid } 1/8-3/8 { Swivel } 6 mm.-8 mm.
KEYS	{ Bit Key } Cast Iron { Tinned Nickled Forged Steel
	{ Flat Keys Folding Cylinder
CYLINDERS	{ Rim Mortise
BACKSET	Distance Front to Center of Knob Hole
SPACING	Distance Center Knob Hole to Center Key Hole
REVERSE BEVEL.	{ Rim Mortise
KNOB STOP.....	{ Rim Mortise
TUMBLERS	Mortise { 1= 3=

Fig. 29. Chart showing principal parts of locks

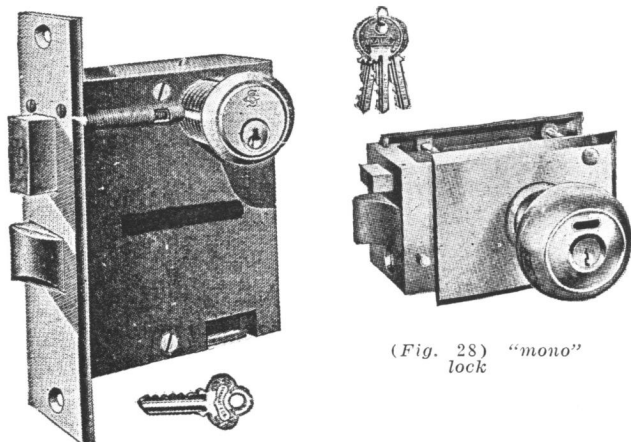
strikes (Fig. 32). If a rim lock is placed on the inside of a door which opens out—such as a closet door—the latch bolt has the bevel reversed; then it must have an angle strike, known as a reverse bevel strike (Fig. 33). This strike is placed on the door stop.

A mortise lock requires a strike that is mortised into the jamb or casing. It is a flat piece of metal with the proper holes to receive the bolts of the lock to which it belongs.

Strikes for mortise locks having latch bolts have a

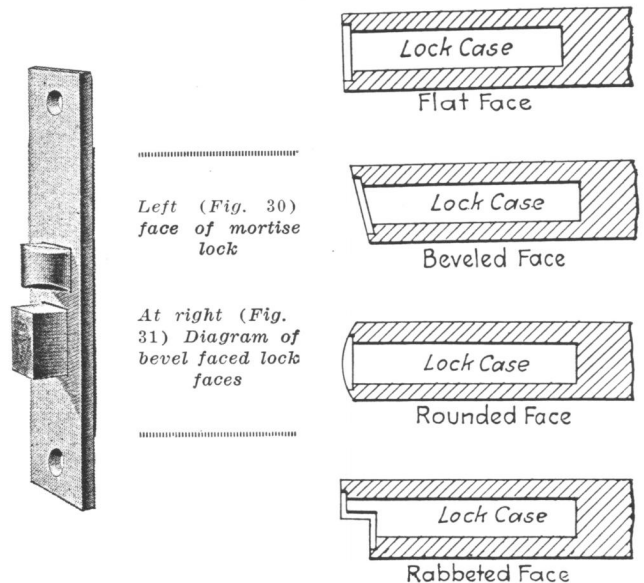
Cabinet and cupboard doors are usually fitted with cabinet locks of the half mortise kind—that is, mortised in flush with the inside of the stile of the door. The face of such a lock is known as the selvedge.

Strikes.—Rim locks ordinarily have strikes set on the outside of the casing. These are known as rim



(Fig. 27) store door lock

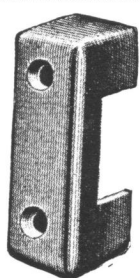
(Fig. 28) "mono" lock



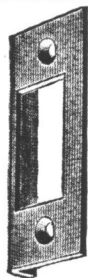
Left (Fig. 30) face of mortise lock

At right (Fig. 31) Diagram of bevel faced lock faces

projecting piece on one side called the lip (Fig. 34). This is for the latch bolt to strike against as the door is closed in order to allow the door to close easily and to protect the casing or trim. The length of the lip is measured from the center of the latch bolt hole to the end of the lip and is known as 1 in., $1\frac{1}{4}$ in. or $1\frac{1}{2}$ in., as the case may be, to the center. The length of the lip is governed by the thickness of the door and



At left (Fig. 32) example of rim strike.
At right (Fig. 33) reverse bevel strike



the amount of extension required to protect the trim. When the extension beyond the thickness of the door is more than $\frac{1}{2}$ in. or so, it should be bent toward the trim so the latch bolt may slip in easily, but when so bent the strikes are handed, providing they cannot be turned either end up.

For high grade work mortise strikes are often made with a box on the jamb side of the strike so that the raw wood cannot be seen through the holes in the strike. This makes a nicely finished job. Box strikes (Fig. 34) are usually handed, however. Some manufacturers overcome the handed disadvantage by making a detachable metal box that is fastened to the back of the strike with screws and can be changed from one side of the strike to the other. This is oft-times a great convenience.

A protected strike (Fig. 34) is one made with an angle at the stop side of the strike and standing at right angles to the strike. This is to prevent the latch bolt being pushed back from the outside of the door by inserting a wire, knife or thin piece of steel under the door stop.

In the preceding articles mention has been made of different types of lock bolts: The latch bolt, operated by a knob; the dead bolt, operated by a key or small knob; the slide bolt, pushed in and out by the thumb or finger. In addition to these there is still another type of bolt, principally used in mortise locks. It is known as an auxiliary or guard bolt. It is placed in the face of the lock near the latch bolt. There is

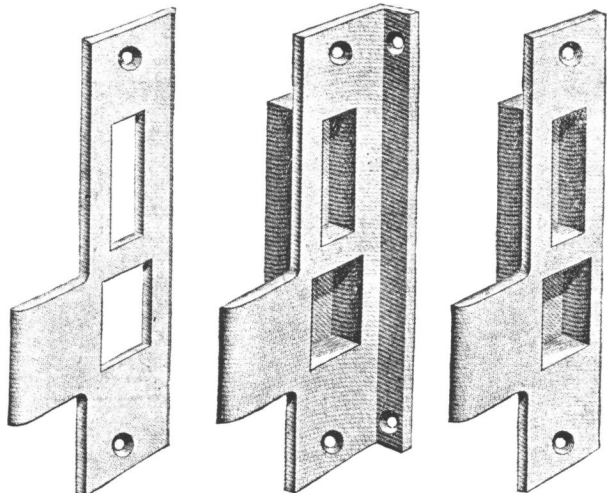


Fig. 34. Strikes for mortise locks

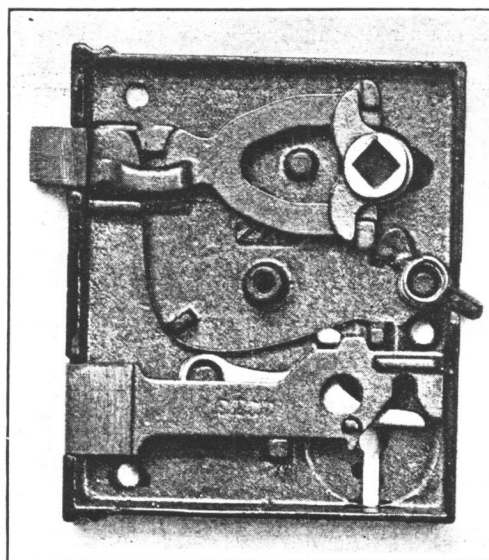


Fig. 35—Interior of stiff spring lock

no hole in the lock strike for it to enter, consequently when the door is closed the guard bolt is pushed back into the lock and held there. In doing this a lever is thrown behind the latch bolt within the lock so that the door cannot be opened from outside by forcing back the latch bolt—in that way guarding the latch bolt. By a key arrangement the lever may be released and the latch drawn back so that the door may be opened.

Latch bolts are sometimes made in two pieces, arranged to work one against the other, as a lever, to reduce the friction in closing the door. These are called anti-friction latch bolts. They are seldom used now, as the plain latch bolt with proper spring arrangement is simpler, just as efficient, and therefore better.

Another form of latch bolt is hinged at one side of the lock case and the other side of the bolt turns back into the lock case instead of pushing straight back. These are known as car latch bolts—from the fact that most locks on car doors have this style of

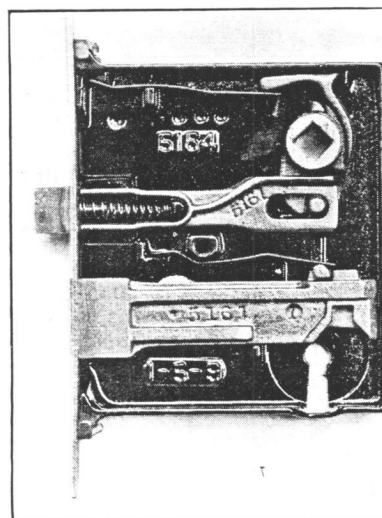


Fig. 36—Soft spring lock

bolt. They are quite effective in reducing friction, but unnecessary except, perhaps, for a heavy lock.

The spring arrangement for controlling the latch bolt is a very important point in the satisfactory working of a lock. The simplest form is one flat steel spring to work with equal strength on the latch bolt and the knob. This does not make an easy-working lock, as the latch bolt works stiff and slams against the lock strike when the door is swung closed, unless the bolt is retracted by the knob. That is not always convenient. Locks of this type are known as stiff spring locks (Fig. 35) and are of the cheapest kind. In order to overcome this annoyance, without much increase in the cost of the lock, two springs of less stiffness are used—one to work independently on the latch bolt, allowing it to work more freely. Both springs are brought into action to give suitable strength when the knob is used. These are known as soft spring locks (Fig. 36) and give reasonable satisfaction when price is a very important item. Locks a grade better than these are made with one coil spring placed in such a way as to be extended by a lever when the latch bolt is pushed in. This lever arrangement overcomes the strength of the spring and allows the latch bolt to

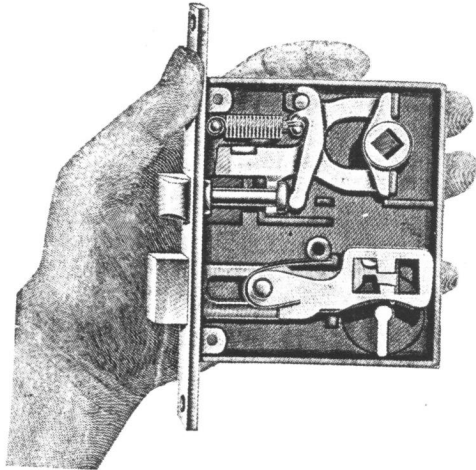


Fig. 37—Easy spring lock

work easily. When the lock is operated by the knob the spring is directly extended and has its full force. This is known as an easy spring lock (Fig. 37) and is a very satisfactory lock for less expensive work.

Higher grade locks are made with what is known as the double compression spring arrangement (Fig. 38). One spring is compressed directly by the action of the latch bolt. This is of proper strength to insure a lively latch bolt action but at the same time allows the bolt to be easily pushed back into the case when the door is closed. An additional spring is compressed when the knob is operated, giving a stiff knob action. This style of lock, of the proper size and type, is suitable for the best work.

Narrow Stile Locks

Narrow stile or narrow backset locks are usually operated by lever handles instead of knobs, the reason for this being that the narrow backset brings the knob so near the edge of the door that the hand is apt to be injured in opening or closing the door. The lever handle allows the hand to be further from the

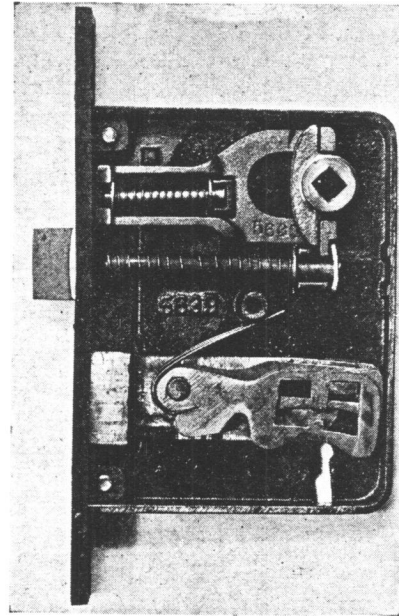


Fig. 38—Double compression spring arrangement

edge when operating the lock. These locks should be equipped with a strong spring arrangement to work against the lever handle. The knobs are balanced and throw none of their own weight against the lock spring—while lever handles have their weight entirely on one side. This weight must be carried by the spring, and for this reason the spring must be strong enough to hold the lever handle up in position. Droopy lever handles have a decidedly careless appearance. This spring strength is accomplished in several ways. Some locks have what is known as a French spring, others a gun spring. When a very heavy lever handle is used, it is often necessary to have an auxiliary spring arrangement in the rose or escutcheon to carry the weight.

The Hub of a Lock

The hub of a lock is that part into which the knob spindle is placed to turn back the latch bolt. There are two general kinds of hubs, the knob hub and the thumb knob hub. Knob hubs are made to receive $5/16$ -in. or $3/8$ -in. spindles. They are either solid (in one piece) for what is known as a straight spindle, or they are split hubs (in two pieces) to receive what is

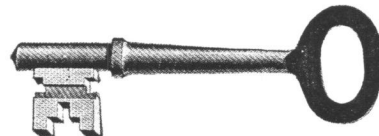


Fig. 39—Bit Key

known as a swivel spindle. The latter type is used in locks where the outside knob is required to be set stationary, at the same time allowing the inside knob to operate the latch bolt. Except for cheaper front

entrance door locks, split hubs are for $\frac{3}{8}$ -in. spindles.

Thumb knob hubs are made to receive thumb knob spindles $\frac{3}{16}$ -in. or $\frac{5}{16}$ in., the latter size in heavier locks. For communicating doors, having the thumb bolts operated from each side of the door, these hubs are split in two pieces, each piece operating its own dead bolt from its own side of the door.

Hubs are made of iron or bronze, iron hubs being used in all cheap locks. It has been the custom to use bronze hubs in high-grade locks, but they do not wear

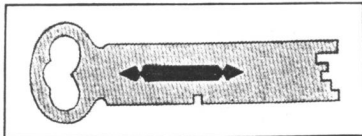
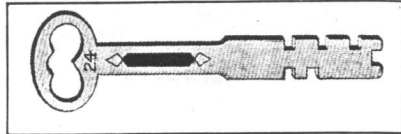


Fig. 40—Flat steel keys

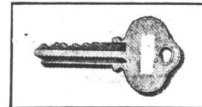
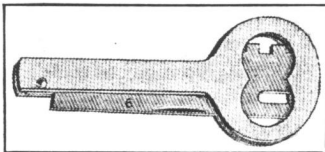
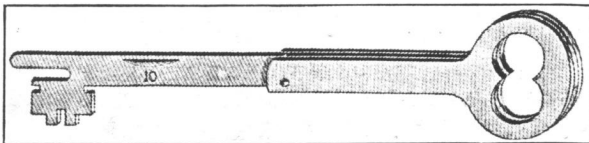


Fig. 41—Folding keys above and at left. Fig. 42—Cylinder key at lower right

as long as iron hubs and for this reason many better grade locks are now made with iron hubs. They are not necessarily considered a mark of cheapness, since utility is of first importance.

The knob stop is a device for making the knob stationary. In rim locks this is a small movable iron piece, one end projecting from the lock case to be moved in such a way as to obstruct the turning of the knob (Fig. 35), in this way quite effectually locking the door against knob or key.

Stops are arranged in mortise locks that are used for entrance doors. Generally the stops are placed in the lock to make only the outside knob stationary, so entrance can be had only by the use of the key. The inside knob can be operated while the outside knob is stationary. These stops are usually arranged like a walking beam—the ends of the stops projecting, like buttons, through the face of the lock. When one of the buttons is pushed in, the inside end engages in a notch in the outside piece of the hub, making it inoperative. When the other button is pushed in, the stop work is released, allowing the outside knob to be operated. In some locks the stop work is operated by a key instead of by the button. This is done so that the stop work cannot be tampered with except by those having the proper key.

The term "spacing" is used to designate the distance between the center of the knob hub and the center of the key hole or between the center of the knob hub and the center of the thumb knob hub.

Keys are of several kinds. Bit keys (Fig. 39), for cheap locks, are of iron, either tinned or nickel plated, while for better grade locks they are made in one piece of forged-steel; flat keys of steel (Fig. 40); folding keys (Fig. 41) are of steel arranged to fold in the manner of a pocket knife—they are used with rim store door locks, which are now largely replaced by cylinder locks and cylinder keys (Fig. 42) of nickel silver for use with locks having cylinders.

The security of locks is accomplished by an arrangement of what are known as "tumblers." In bit-key locks and flat-key mortise locks the tumblers are made of flat steel and placed in the lock in a position near the key bolt. In the form most commonly employed there is a small round hole in one end of the tumbler which is placed over a post in the lock case. The other end of the tumbler has a projection which obstructs the movement of the keybolt in or out. By inserting a key with cuts in the bit which correspond with the height of the projection on the tumbler, the key may be turned, thereby raising the loose end of the tumbler on which is the projection, permitting the key bolt to be moved in or out as desired.

Number of Tumblers Varies

The projections on the tumblers are made of different heights so that all locks may not be operated by the same key, as each height of projection requires a key with a corresponding cut in the bit. The number of tumblers used varies from one to possibly six—one tumbler for the less expensive locks, where it is not essential to have much security. Three tumblers are used in the ordinary good grade of locks, and each of the three tumblers has a different height of projection. All three projections must be brought into line in order to allow the key bolts to pass, and the notches in the bit of the key must be made to correspond with the tumbler projection. It is evident that it is more difficult to manipulate the three tumblers into proper position (except with the right key) than it would be one tumbler. For this reason

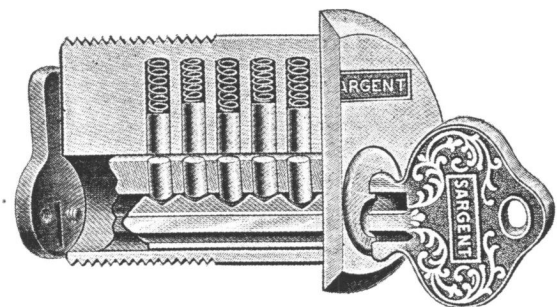


Fig. 43—Showing interior mechanism of cylinder lock

the three (or more) tumbler locks afford a greater degree of security.

In addition to the tumblers there are wards placed in locks. Side wards are small projections on the side of the keyhole. A corresponding groove must be cut in the side of the bit of the key in order to allow it to

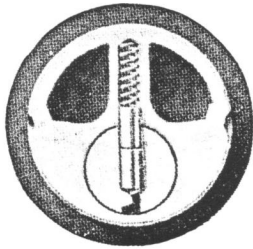


Fig. 44—Cross-section of cylinder, pin-tumbler at bottom

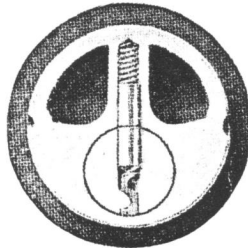


Fig. 45—Pin-tumbler raised by key to correct position

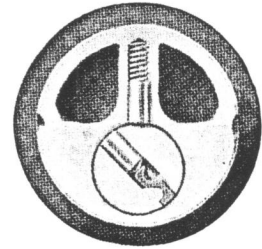


Fig. 46—Plug partly rotated, carrying cylinder with it

enter the keyhole. These side wards are placed in different locations in different keyholes, which requires the keys to be grooved in different places. Then there are wheel wards, which are small projections placed on the cap of the lock in the path the key takes when turned in the keyhole. To turn the key past these wheel wards, corresponding notches must be cut into the edge of the bit of the key. The wheel wards also are placed in varying locations, each requiring the proper notch in the key.

These three features, the tumblers, the side wards and the wheel wards, make up the security of the lock. In order to operate the key bolt, the key must have the particular cuts to correspond with the tumblers, side wards and wheel wards.

It will be seen that the varying position of these three features makes possible quite a number of different combinations. Each combination is known as a "key change." It is practical to make one tumbler lock having these three features with about fifty changes, all different, while similar three-tumbler locks are ordinarily made with 100 changes, all different.

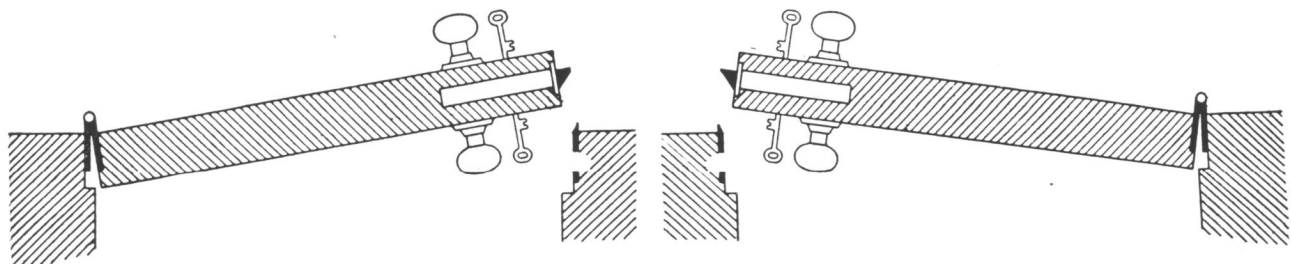
Medium grade locks having one wrought steel tumbler and with keys not using side wards, but having

wheel wards, the number of key changes varies from sixteen to twenty-four.

Very cheap locks have the tumblers of cast iron and are alike for all locks of one type or class. In these locks the changes are accomplished by the wheel wards, so the number of changes is usually twelve.

Security in the Cylinder

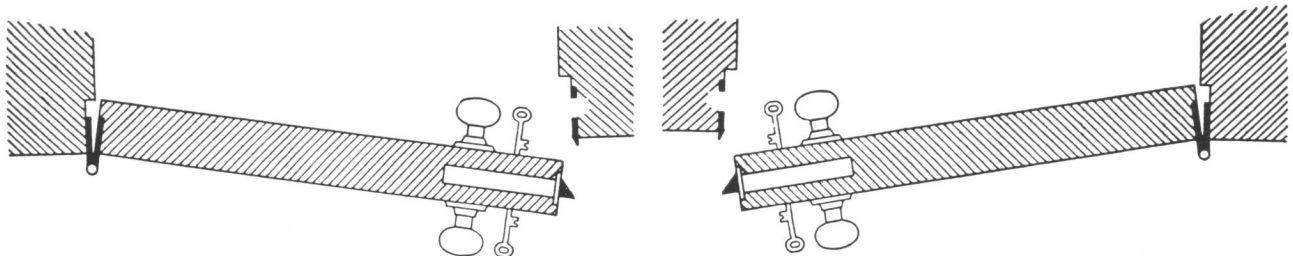
Cylinder locks have the security in the cylinder. It is accomplished by what is known as pin tumblers (Fig. 43). In less expensive locks four sets of pins are used, in the better grade of locks there are five sets, while for locks used in large buildings requiring a special keying system cylinders with six sets or seven sets of pins are used. The cylinder mechanism consists of the cylinder or shell, into which is fitted a plug. In the plug is slotted lengthwise a keyway having side wards, and the keys must have corresponding grooves on their sides. Each set of pins consists of a tumbler pin which rests in the plug. These are of varying lengths. Above the tumbler pin is a similar pin known as a driver. The drivers are all of one length, and when the key is not inserted stand across the divisions between the cylinder and plug (Fig. 44), thus barring the rotation of the plug. Above the



(Fig. 1) Left hand door, left hand lock

(Outside)

(Fig. 1) Right hand door, right hand lock

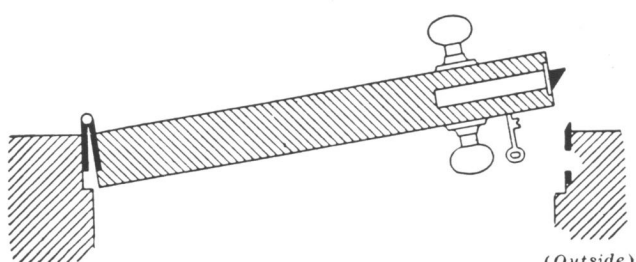


(Fig. 2) Left hand door (reverse), right hand lock

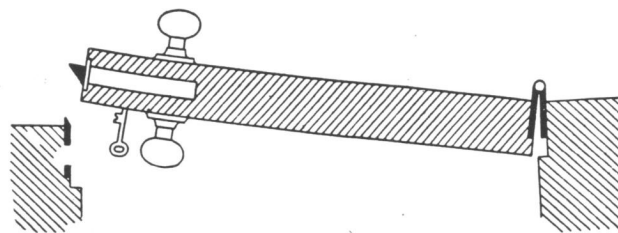
(Outside)

(Fig. 2) Right hand door (reverse), left hand lock

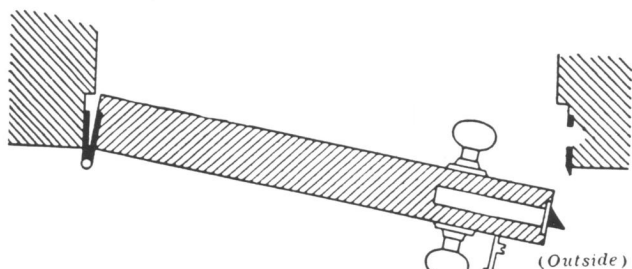
FOR MORTISE LOCKS HAVING THE SAME KEY-FUNCTIONS FROM BOTH SIDES OF THE DOOR



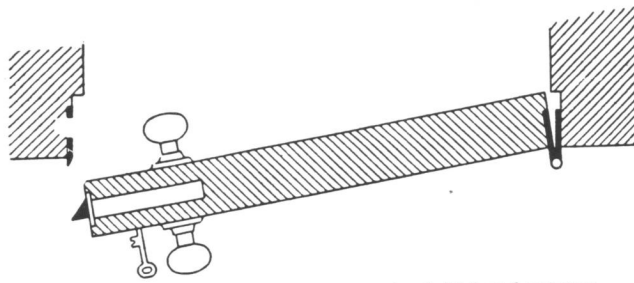
(Fig. 3) Left hand door, left hand lock



(Fig. 3) Right hand door, right hand lock



(Fig. 4) Left hand door (reverse), left hand reverse bevel lock



(Fig. 4) Right hand door (reverse), right hand reverse bevel lock

FOR MORTISE LOCKS NOT HAVING THE SAME KEY FUNCTIONS FROM BOTH SIDES OF THE DOOR

driver is a spring which holds the driver and tumbler in their proper position. On the end of the plug is a cam which rotates with the plug. In the key must be cut notches of varying depth, corresponding with the lengths of the tumbler pins. When inserted in the plug, a key so cut will raise the tumblers so the division between the tumblers and drivers will line up (Fig. 45) at the division between the cylinder and plug, thus allowing the plug to rotate (Fig. 46). As the plug is rotated, the cam comes into action with the bolt throwing it in or out as desired.

The variations of the side wards and the lengths of the tumbler pins make possible a very large number of key changes. Cylinder locks possess the highest security and the greatest possibility for key changes. Cylinders should always be put in the lock so the springs and drivers will be above the tumbler pins.

When a number of locks are to be used in one building or in a group of buildings it is often convenient to have them master keyed and possibly grand master keyed.

Master Keys

This means that the locks are made of different key changes, but arranged so a special key—known as a master key—will open any lock in a certain group. They can also be made so another key known as a grand master key will open any lock in several groups. Master keying and grand master keying is done for convenience and does not add to the security of the locks. Different manufacturers accomplish the above keying in different ways, and all locks have not the same keying possibilities. So special care should be taken to study carefully the descriptions and instructions given in the catalog of the manufacturer whose locks you are planning to use.

Complicated keying layouts can be worked out by most of the makers of good locks. It is desirable, however, to keep them as simple as the convenience of the occupant of the building will allow. Simple things are usually best and give the most lasting satisfaction.

Reference has been made in preceding pages to reverse bevel locks, to right-hand locks, left-hand locks and reversible locks. This is an important item of lock knowledge and one that requires some experimenting to get well fixed in one's mind.

The term "reverse bevel" means that the bevel of the latch bolt is turned in the "reverse" or opposite direction from its "regular" or usual position in locks of its kind or type.

When applied to rim locks and latches, it means they are properly set up to be placed on the inside of doors that open out. Locks so applied must have an angle strike placed on the door stop, as described in an earlier article. The latch bolt must have the bevel reversed so the flat side will be toward the door, then the beveled side will strike against the angle strike, thereby allowing the door to close.

"Reverse Bevel" Mortise Locks

For mortise locks the term "reverse bevel" should be applied only to such locks as are not operated the same way from each side of the door—such as front door or office door, or hotel corridor door locks, when they are applied to doors opening out of instead of into a room. In such cases the flat side of the latch bolt must be turned toward the outside of the lock, while in regular bevel locks (not "reverse bevel") the flat side of the latch bolt is turned toward the inside of the lock. If the face of a reverse bevel mortise lock is beveled, it must be beveled away from the outside of the lock; while for doors opening in (regular bevel locks) the face is beveled toward the outside of the lock. Locks having split hubs for swivel spindles should always be set up so that the portion of the hub that has the notch to receive the stop is placed toward the outside of the lock, so that when the lock is applied and the stop is pushed in or set, the outside knob will be stationary and entrance can be gained only by means of the key.

I am reminded by this of an incident that occurred several years ago. A rather dignified old gentleman

in a town in New York State was building a house. It was to be his home, and he wanted everything to be the best and most convenient. I sallied forth to secure the order for his hardware through the local hardware dealer. The old gentleman made his selection from my samples, including a heavy cylinder lock for his front entrance door. The price was made and he gave me the order. The hardware was sent to him. By the time of my next visit to that town it had been put on. I made it a point to look up the home builder to see that everything had turned out to his satisfaction.

Could Get In But Not Out

He told me everything came all right just as he had selected and was quite satisfactory except, perhaps, the lock for the front door. "If I were doing it again," he said, "I'd select some other kind. I do not quite like the way this one works." "How does it work?" I asked. "Well," he said, "anyone can come in from the outside at any time without the key, just walk right in, but when the stop is set I can't get out of the house without a key unless I go through the window."

I had to admit that I wouldn't much like that arrangement, either, and we'd better look it over. The trouble was that the carpenter when applying the lock had set it up with the notched part of the hub toward the inside of the lock. I got hold of the carpenter, we set up the lock right and replaced it, much to the satisfaction of the old gentleman. I mention this in order to illustrate what an unsatisfactory condition may result from overlooking a very small detail and also to bring out the importance of knowing just what is in a lock and what it is built to do.

Know the Standard Rules

Since all locks are not made so they can be reversed or changed to suit doors hinged on either the right-hand or left-hand side or for doors opening in or out,

it is necessary to know the standard rules for determining the hand of doors and locks. The rules and illustrations given here are taken from the catalogs of prominent lock manufacturers, and I believe that they represent standard practice:

1. The hand of a door is always determined from the *outside*.

2. The "outside" is the street side of an entrance door and the corridor side of a room door. The "outside" of a communicating door, from room to room, is the side from which the butts or hinges are not visible when the door is closed. The "outside" of a pair of twin doors is the space between them. The "outside" of a closet, cupboard or book case door is the room side—thus reversing the rule which applies to other doors.

3. If, standing "outside" of a door, the butts are on the right, it is a right-hand door; if on the left, it is a left-hand door. If, standing outside, the door opens from you, or inward it takes a lock with a regular bevel bolt and the hand of the lock is described the same as the hand of the door (see Figs. 1 and 2), page 9. If the door opens toward you, or outward, it takes a lock with a reverse bevel bolt and the hand of the lock is described as shown by Figs. 3 and 4, page 10.

From the above it will be seen that the description of the hand of the lock for doors opening outward varies according to the type of lock.

As cupboard and book case doors always open out, locks for such doors, commonly known as cabinet locks, are regularly made with the reverse bevel bolts and it is not necessary to specify "reverse bevel." The hand of the lock is the same as the hand of the door as determined by rule 3 above.

Take locks of different kinds from your stock and study them carefully in connection with these rules and diagrams and you will soon be able to know at a glance what "hand" lock will be required for any door.

CHAPTER II.

Knobs, Roses and Escutcheons

WE have now considered the various types of locks, their parts and their functions. These locks, however, save in a very few instances, are not complete in themselves, and must be associated with knobs, roses and escutcheons when applied to the door.

Knobs, roses and escutcheons are made of several different materials and in many designs or patterns. It will suit our purpose best at this time to consider

only the features which are common to all designs, and with this in mind reference will only be made to plain or simple patterns.

Various Kinds of Knobs

Knobs in common use are made of "porcelain" (white), "jet," a clay composition baked with a jet-black glazing, steel, cast iron, brass, bronze and glass. A few years ago many knobs were made with



Fig. 48—Round knob

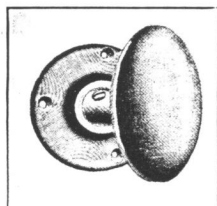


Fig. 49—Oval knob



Fig. 50—Octagonal knob

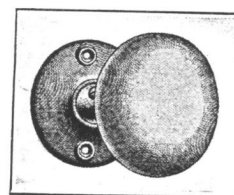


Fig. 51—Porcelain Knob

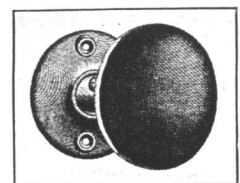
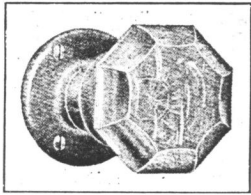


Fig. 52—Jet knob



At the left—Fig. 53.—Glass knob
At the right—Fig. 54.—Side
screw; Fig. 55.—Knob washer;
Fig. 56.—Grub screw



tops of various kinds of woods, but these have been nearly discontinued.

The principal parts of a knob are the top and the neck or shank. The "top" is the part one takes hold of when the knob is turned, while the neck is the part by means of which the knob is fastened to the spindle.

Tops are made in three general shapes—"round" (Fig. 48), "oval" (Fig. 49) and "octagonal" (Fig. 50). They range in size from 1½ in. to 2½ in. in diameter for the round and octagonal shapes, while the oval shapes are in proportion. The standard size in general use is 2¼ in. The small sizes are usually seen in houses of colonial design, while the 2½-in. size is used for front entrance doors, although it is not used as often as in the past, the 2¼ in. being considered a better size except, perhaps, for public buildings. Knobs have been made in many odd and fancy shapes, but these, as a rule, do not meet with a great deal of favor owing to the fact that they do not fit the hand as well as do the standard shapes.

The Necks of Knobs

The necks used for porcelain and jet knobs are usually made of cast iron, brass or bronze, while the necks for glass knobs are of brass or bronze; other knobs are usually made of the same material as the tops.

Porcelain (Fig. 51) and jet knobs (Fig. 52) have the necks leaded into the tops. With japanned iron necks they are the cheapest knobs made, and are used only for cheap work, and especially with cheap rim locks. When made with brass or bronze necks they are

very good knobs of comparatively low cost. Porcelain knobs are particularly desirable for the service portion of dwellings. They give a bright, cheerful appearance, and, as they do not rust or tarnish, are easy to keep clean.

The necks of glass knobs (Fig. 53) are tightly secured to the tops by turning or spinning the metal over a rim on the top. These knobs are at present very popular for residences. Opal glass knobs are quite suitable for bathrooms, service parts of good homes and hospitals. They are not as frail as might be imagined, and the percentage of breakage is small.

There are other knobs, having the tops and necks of the same material, which are either made in one



Fig. 61—Straight side knob screw spindle

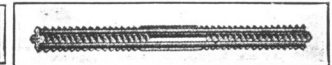


Fig. 62—Straight screwless spindle



Fig. 63—Swivel side knob screw spindle

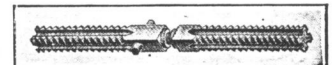


Fig. 64—Swivel screwless spindle

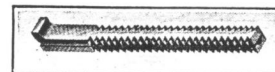


Fig. 65—One knob spindle

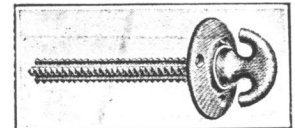


Fig. 66—Screwless closet spindle



Fig. 57—Triplex straight spindle.

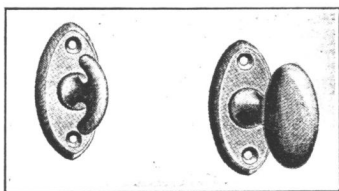


Fig. 58—Thumb knob and oval knob

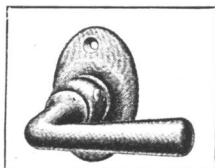


Fig. 60—Plain lever handle

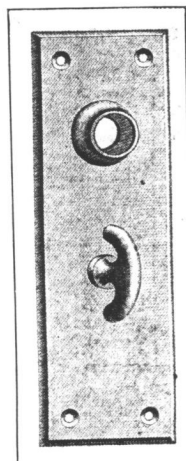


Fig. 59—Elongated rose and escutcheon

piece or have the two parts screwed or spun together in such a way as to make them practically inseparable.

The majority of manufacturers make their knob necks in two sizes. The smaller size, which is about 10/16 in. or 11/16 in. in diameter, is known as the "standard" or "regular" neck. They are used in instances where the knobs are fastened to the spindles by means of screws (Fig. 54), known as side knob screws, through the neck into threaded holes in the spindle. This is an old and cheap method and its chief disadvantage lies in the fact that it does not afford a satisfactory adjustment of the knobs to different thickness of doors because the screw holes in the spindles cannot be placed less than ¼ in. apart (Fig. 61). Washers (Fig. 55) must be used for adjustments between these ¼ in. spacings, but do not insure a close fit.

An improvement over this method of attaching the knob to the spindle is often accomplished by making the neck larger in diameter, about 14/16 in. or 15/16 in., threading the holes in the necks and screwing them on to a threaded spindle (Fig. 62). This allows them to be secured to the spindle at any quarter turn, and, therefore, insures a perfect adjustment. The increased

size of the neck makes a better bearing or seat for the knob against the rose or escutcheon bushing.

One method of securing this type of knob to the spindle is by means of a grub screw (Fig. 56) into a threaded hole in the neck. When this screw is set down hard against one of the flat sides of the spindle the knob is held firmly.

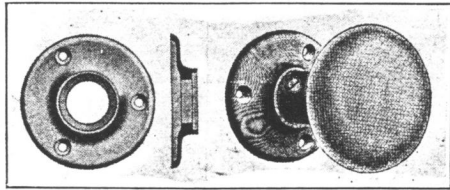


Fig. 67—Rose and screwless spindle knob

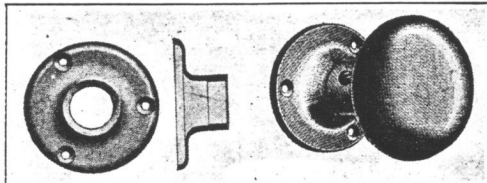


Fig. 68—High bracket bearing rose and knob

Another method is by means of an adjusting nut concealed in the neck of the knob. There are several types of these and each manufacturer has his own particular device. This is a very satisfactory way of securing the knobs, for if the work is well done they do not work loose. They do, however, cost a little more than the grub screw type.

One maker (Fig. 57) uses a spindle composed of three pieces. The neck has a square hole and is slipped on to the spindle to the desired adjustment and is secured by a grub screw set down hard against one of the pieces of the spindle, forcing it between the other two pieces. This serves to bind the knob and spindle tightly together. These several means of adjustment (except the standard with side knob screw) are known in the trade as "screwless spindle" knobs. The particular type desired must be described as directed by the catalog of the maker whose line of goods you are selling.

Thumb Knobs and Lever Handles

"Thumb knobs" are small knobs used to operate the bolts of locks from the inside of the door when it is not convenient or necessary to have such bolts operated by keys. They are used on front doors, bathroom doors and communicating door locks. They are sometimes mounted on a small plate (Fig. 58) and frequently on the combined rose and escutcheon (Fig. 59). They usually have 3/16 in. spindles.

Lever handles (Fig. 60) are made in many patterns and are sometimes used instead of knobs. With "narrow stile" or "short backset" locks they are needed in order to protect the hand from injury when the door is being opened. Sometimes a lever handle is used on one side of a door of this kind and a knob is used on the other side. In such cases the lever handle must be placed on the outside for doors opening in and on the inside for doors opening out.

Types of Spindles

This is probably a good place to show the several common types of spindles.

Fig. 61 illustrates "straight-side knob screw" spindles while Fig. 62 shows the "straight-screwless"

spindle. These two are used for locks having solid one-piece hubs and knobs operating the same from both sides of the door.

Fig. 63 shows the "swivel-side knob screw" spindle while Fig. 64 illustrates the "swivel-screwless" spindle. These are for locks having two-piece or split hubs allowing the outside knob to be set stationary while the inside knob may be operated.

Care must be used in placing the swivel in the center of the hubs, in order that either side may operate independently. When using the makes of spindles that are fastened together at the swivel by screwing one end into the other, they should not be screwed tightly together, by one full turn, before being placed into the hub. If they are screwed too tightly they will not work freely and may strip the thread in using.

Fig. 65 is the type of spindle used when a lock is operated only from one side by a knob, such as a front door lock operated from the outside by a handle and thumb piece and from the inside by the knobs.

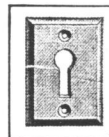
Fig. 66 shows a spindle frequently used on closet doors where a knob is not required on the inside, save in emergency, in which case the small thumb piece on the closet end of the spindle may be used to open



Fig. 69—Keyhole escutcheon, round



Fig. 71—Drop escutcheon



Square

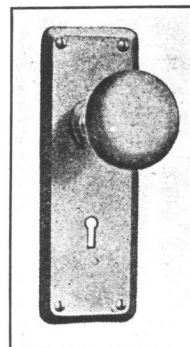


Fig. 70—Combined rose and escutcheon



Fig. 72—Threaded escutcheon

the door from the inside. This has the advantage of being less expensive than a full pair of knobs.

Spindles for porcelain, jet or glass knobs are usually 3 3/8 in. long, while for knobs having hollow tops, steel, brass or bronze, the spindle may be 4 in. or 4 1/2 in. for a door of unusual thickness. For thicker doors the spindles must of course be longer.

All of these spindles are furnished for either 5/16 in. and 3/8 in. hubs, and should be large enough to snugly fill the hole in the hub or there will be unnecessary "play." This is particularly noticeable when lever handles are used.

Roses and Their Uses

Roses (Fig. 67) are the pieces placed around the hole in the door through which the spindle is put into the hub of the lock. They are usually round and frequently ornamental, which no doubt accounts for their name. They are made so as to form a seat or bearing for the neck of the knob, and for that reason their proper fit has much to do with the rigidity and satisfactory working of the knobs. There is a type of rose (Fig. 68), used with screwless spindle knobs, known as a "high bracket bearing rose." With this style the neck of the knob is on the top rather than

down in the rose. It is an open question whether this type is as satisfactory as the other kind. If the knob is not put straight through the door the bearing on top of the rose will not be true, and will neither look as well nor operate as well as in the more compensating kinds.

Roses are generally made of steel, brass or bronze, although porcelain roses are occasionally used with porcelain knobs with less frequency each year.

Escutcheons and Their Uses

Escutcheons, so called because originally they were used to shield the keyhole, are of two general types. The small ones are only large enough to shield the keyhole (Fig. 69). The ones combining both the rose and keyhole shield in one long piece are known as "rose and escutcheon combined" or "elongated escutcheons" (Fig. 70). They are made of steel for very cheap work and of brass or bronze where better work is desired.

"Elongated roses and escutcheons" are made with the bearing or seats to receive the end of the knob neck in the same manner as roses do. These bearings or seats are known as "bushings," and must be of proper size and shape in order to fit the knob neck.

"Keyhole escutcheons" are usually used in the very plain and simple patterns, and are particularly suited for homes of colonial design. Some reproductions of old patterns have movable pieces which drop over the keyhole (Fig. 71) and are known as "drop escutcheons."

There is another form of escutcheon made of brass or bronze in the shape of a keyhole. These are let

into the wood as a sort of lining for the keyhole and show only a narrow rim or thread of metal around the keyhole. These are called "thread escutcheons" (Fig. 72) and are used principally in old-fashioned cabinet work.

When separate roses and escutcheons are used it is commonly called "sectional trim." For very cheap work on thin doors the combined rose and escutcheon has the advantage of being long enough to bring the screws above and below the case of the lock, and, therefore, the screws may be longer and fasten the escutcheon more securely to the door. For public buildings, hotels and offices, intended for much use for many years, the long escutcheon is favored for the same reason. However, where the doors are thick enough, there is a growing tendency toward "sectional trim"—because of its extremely neat appearance and lack of unnecessary display.

Knobs, roses and escutcheons of the less expensive kinds are made from sheets of cold rolled steel, brass or bronze, blanked out and formed into shape and design on presses, some of which have a pressing power equal to 1000 tons. When so made they are referred to as "struck-up," "pressed," "stamped" or "wrought." The word "wrought" is perhaps a better description, as it does not suggest a tin-like effect. Incidentally, the metal used ranges in thickness from 28/1000 to 50/1000 of an inch and it is quite strong enough for the work for which it is intended. The better grades of goods are made of cast brass and bronze, and it is desirable to use the better type whenever the expense will permit.

CHAPTER III.

Fire Exit Bolts

THE many very serious fires in school buildings, office buildings, churches, theaters and factories, resulting in appalling loss of life because of inadequate exit facilities have induced the enactment of very strict building and fire regulations in every town and city throughout the country.

Those who are responsible for the care of places where numbers of people are assembled for pleasure or work are insistent that all such places be built with ample means of exit, and that all exits be equipped with the most modern and efficient hardware. This hardware must be strong and durable, securely hold-

ing the doors against entrance when closed, yet releasing the doors instantly and automatically from the inside under the most trying and confusing circumstances.

It must not be necessary to *know how* to open such doors, the locks and bolts must not *stick or jam*, the doors must *not bind*—they must *just open*.

This demand has resulted in the perfection by several manufacturers of what is known as fire exit bolts, bolts that operate automatically, yet properly controlled by latches, locks and keys to meet the most exacting requirements.

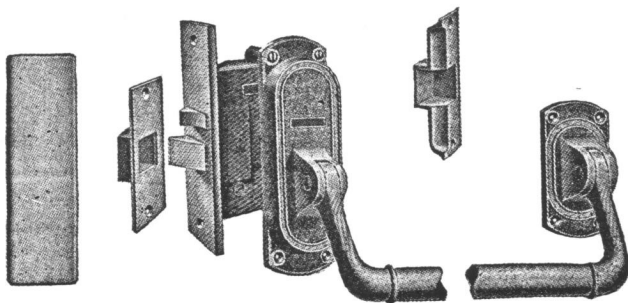


Fig. 73—Fire exit bolt opening only from inside. At left, plate for outside of door. Above Fig. 77—Open strike

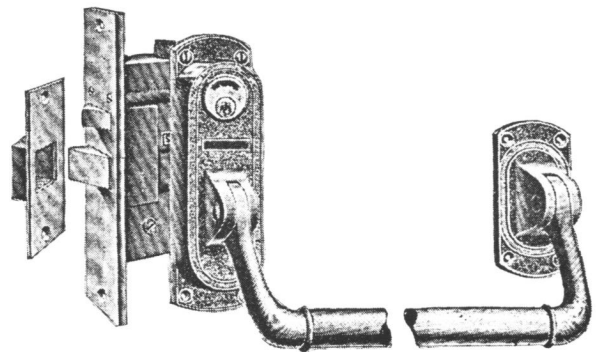


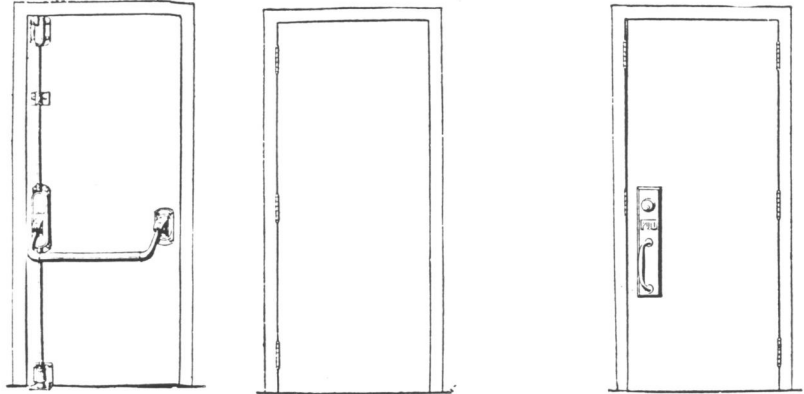
Fig. 74—Fire exit bolt for doors used for entrance and exit opening out. Door pull on outside

How the Door Opens

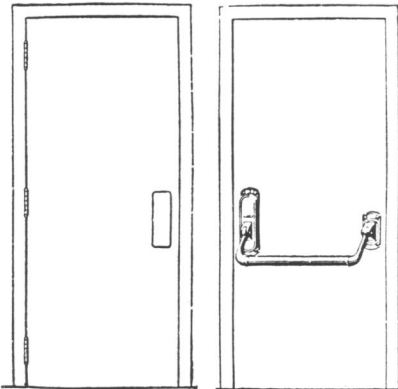
Pressure on the cross bar at any point releases the latch bolt and the door opens. The latch bolt is protected from being pushed back from outside either by the auxiliary dog bolt, shown herewith, or by the

There has grown up a big demand for these everywhere, and they should be studied, so that proper selections may be made to meet each particular place. To assist in this I have, for convenience, taken the liberty of using illustrations from the catalog of one maker, with no intention of pointing out any of its special merits. There are several manufacturers who make very similar devices, each performing its purpose in much the same way. It is true that each maker has devices of merit peculiar to his own make, but I shall purposely avoid mentioning any of these special points here and speak of the general features only.

The principal feature of all these bolts is a bar extending across the width of the door, usually about 36 in. from the floor. One end of this bar is hinged to a small plate on the hinge-stile of the door, the other end is connected with a "center-case" on the lock-stile of the door. This center-case is connected either with a latch, or a lock or with rods to operate bolts



At left, supplementary Fig. 75—Door opening only on inside. Extreme right, Fig. 76—Outside of door operative from both sides



At left, supplementary Fig. 73 showing inside and outside of door

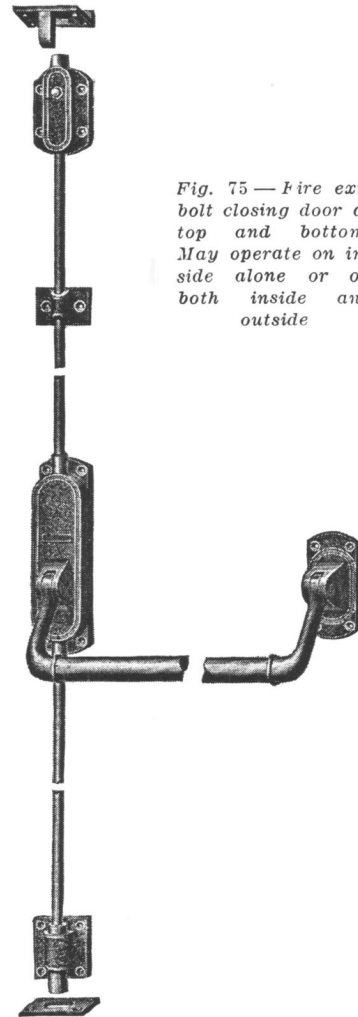
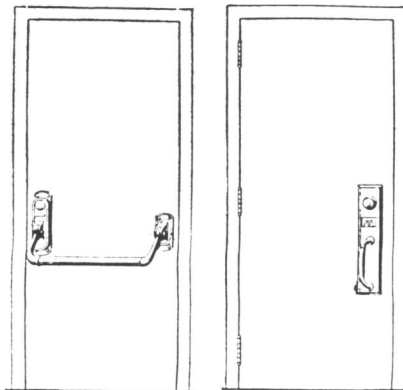


Fig. 75 — Fire exit bolt closing door at top and bottom. May operate on inside alone or on both inside and outside

at the top and bottom of the door. A slight pressure on this cross bar, at any point, will operate the latch, lock or bolts instantly, releasing them and the doors open.

The simplest form is for a single door for exit only—no entrance from outside. See Fig. 73.



At right supplementary Fig. 74 showing inside of door with pull on outside

latch having a recessed face and strike, which is equally effective.

Another form of this bolt is for a single door used for both exit and entrance. This bolt operates from inside in the same way as the one shown in Fig. 73, in addition to which entrance may be had from outside by means of a cylinder key and a door pull, door knob, or thumb piece and handle. If desired, at times, to have free passage in or out, the latch bolt may be held back in the lock case by a turn of the cylinder key in the inside cylinder. See Fig. 74.

Top and Bottom Bolts

Another form of bolt has the cross bar the same as the bolt shown in Figs. 73 and 74, but the doors are secured when closed by bolts at the top and bottom of the door. These bolts are drawn from their keepers or strikes by pressure on the cross bar, and are held retracted until the door is again closed. In closing they are released when the top bolt comes in contact with its keeper or strike and the doors are automatically secured.

Bolts of this type are furnished for exit only (Fig. 75), with nothing on the outside of the door, or they may be had to be operated from the outside by a key and handle or knob (Fig. 76) and in that way may be used as entrance as well as exit doors.

These are especially good exit bolts for doors already in place where there may be trouble in properly fitting a lock or latch.

As shown above, the different types of exit bolts have been described as applied to single doors. They may be applied to pairs of doors by combining the top and bottom bolt shown in Fig. 75, with another of the same kind, or with any one of the other three shown in Figs. 73, 74 or 76.

For pairs of doors, one bolt of the type of Fig. 75 should always be used to firmly secure one of the doors so the other door may be closed against it. If a bolt having a mortise lock or latch is used on a pair of doors it must have what is known as an open strike, such as Fig. 77, so either door may be closed first and not injure the latch bolt.

What to Specify When Ordering

When ordering fire exit bolts it is necessary to specify the height, width and thickness of the doors, single or in pairs, or the width of stiles. These bolts are not generally reversible so the "hand" of bolt must be specified, as described in the catalog of the manufacturer whose bolts you are using. Study all the special features of the bolts you are selling so as to be familiar with their possibilities, but use the most simple device you can, that will meet the requirements of your customer.

CHAPTER IV.

Butts and Hinges

THE word "hinge" probably comes from the same source as the word "hang"—and so we have the common expression "The carpenter will *hang* the door"—meaning "The carpenter will *hinge* the door." Hinges are usually made of iron or steel and sometimes of brass or bronze. They have a jointed center one or both sides of which extends into a long strap. They are made to fasten to the side, or surface, of the door or gate and to the jamb or post to which it is to be hinged. See Fig. 78 for a present common form of hinge.

Ancient and Modern Hinges

Until comparatively recent years hinges were made by the local blacksmiths. In early English times they were wrought into very elaborate and ornamental designs, frequently extending over the entire surface of the door in a network of scrolls and vines. The wrought iron hinges on the doors of the Cathedral of Notre Dame in Paris, made in the thirteenth century, are the finest examples of their class. Ornamental hinges of this sort are now made by a few art metal workers for use on church doors and other doors of similar nature where the architectural treatment demands them.

It is rather common now, however, to have the ornamental scroll portions made separate from the jointed portions, in which case they are known as "hinge plates." They may be of wrought iron, or of cast iron or cast brass or bronze. Sometimes they are rather elaborate (Fig. 79) and sometimes they are quite simple. In any case, they are for ornaments only and should never be used except where they harmonize with the doors and general character of the building. They do not belong on doors of modern design.

A "butt" is the large or jointed part of a "hinge"—omitting the straps. It is the butt end of a hinge

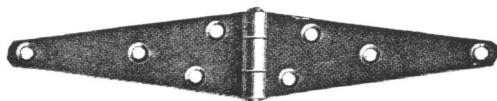


Fig. 78—Common form of hinge

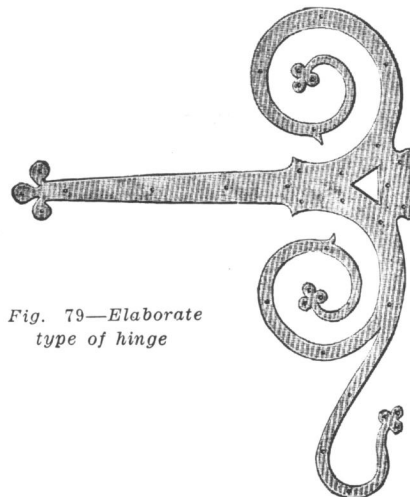
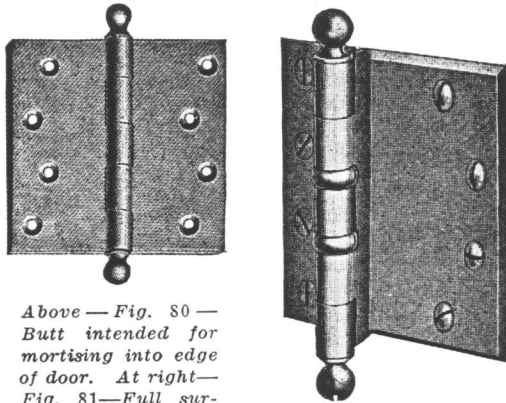


Fig. 79—Elaborate type of hinge



Above—Fig. 80—
Butt intended for
mortising into edge
of door. At right—
Fig. 81—Full sur-
face butt

which accounts for the name "butt." There is not a very clear cut line drawn between the names "hinge" and "butt." The word "hinge" is often used in connection with what should theoretically be called a butt; however, the word "butt" is seldom, if ever, used to describe a long strap hinge. Butts are commonly intended to be mortised into the edge of the door (Fig. 80), although a few styles are made to be applied to the side or surface, and are known as surface butts (Figs. 81 and 82).

The round central portion is known as the "knuckle." It is ordinarily divided into five sections and then is known as a "five-knuckle butt." The flat parts are known as the "leaves" or "flaps." The two flaps are held together by a pin running through the knuckles. In the illustrations you will note there is a small ball at each end of the pin; butts so finished are known as "ball tip butts." Sometimes these tips are rounded off like an oval head rivet and then are known as "button tips." The French make butts with very ornamental knuckles and tips. Generally door butts are made so the pins may be taken out, and are known as "loose pin butts." When the pins are not removable, the butts are known as "fast joint."

Materials Used

Butts are made of wrought steel, cast iron, wrought brass or bronze, and cast brass or bronze. Each of these materials has its advantage in one way or another, and in considering these reference will be made particularly to butts intended for passage doors.

Of course, butts made of cast iron or steel cost less than those made of brass or bronze, and for this reason are used in much larger quantity. Formerly all cheap butts were made of cast iron, but they were not particularly well finished. Then came the rapidly improving methods of shaping sheet steel with dies, presses and punches, and wrought steel butts were made. Being made of cold rolled steel, they are susceptible to a fine finish at a low cost. As they are beautifully made and present a very fine appearance, they have grown into great popularity. They are quite suitable for interior use where the doors are not too heavy and not too much used and where expense clamors for consideration. As these are of steel and are not hardened, I feel they have not the wearing quality in their simple form to recommend them for use on heavy doors, doors much used, or doors controlled by springs and checks.

Cast iron butts of heavy weight are now made and are given a very fine finish, but their cost is slightly

more than equally well finished steel butts. As cast iron is quite hard, butts made of it are very long wearing and, if they are of proper size, will carry heavy and much used doors satisfactorily for many years.

Butts made of cast iron or steel are likely to rust, and for this reason I do not consider them satisfactory for exterior use, nor for use in damp places, or in places where a showing of rust, even though slight, would be unsatisfactory. To overcome this tendency to rust they may be zinc plated or sherardized before being bronze or brass plated, but even this I do not consider sufficiently rust resisting to justify their use in such trying places as mentioned above. The next grade of butts, price considered, are made of heavy sheets of brass or bronze formed into their shape in the same manner as wrought steel butts. To increase their wearing quality they are reinforced at each joint with two steel bushings and have the hole for the pin interlined with steel (Fig. 83). Butts of this kind are known as "wrought brass or bronze butts."

The next grade of butts are made of cast brass or bronze. They are made by most manufacturers in three weights, and are double steel bushed at each joint. Brass and bronze butts will not rust, and so far as that goes are suitable for use in any climate and any place. When furnished in the natural color of the metal they may be polished and kept in their original bright and shining condition for years.

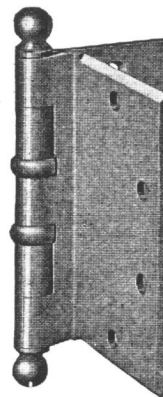
Ball Bearing Butts

To improve the wearing quality of steel and brass or bronze butts, they are also made with ball bearings at two or more of the knuckles. These bearings have tool steel balls running in hardened steel raceways inclosed in an outer protecting jacket of either brass or bronze. These should be secured to the butt so they will not fall out when the pins are removed for hanging the door. As cast iron butts are much harder than those made of steel, brass or bronze, they are not generally equipped with ball bearings.

The size of a butt is described by giving first the height of the body of the butt (not including the tips) in inches, then the width when open in inches. Thus, a butt described as 4 in. by 3 in. is 4 in. high and 3 in. wide when open. They are, however, usually made in square sizes, that is, 3 in. by 3 in., 4 in. by 4 in., etc.

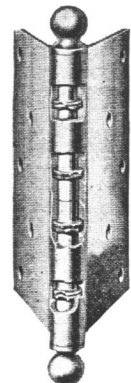
Determining the Proper Size

To determine the proper size butt required for a given door is rather simple. Refer to the sketch (Fig. 85). In this sketch the door is $1\frac{3}{4}$ in. thick, the trim in $1\frac{3}{8}$ in. thick. The butt is not mortised entirely



At left—Fig. 82—
Half surface
butt.

At right—Fig.
83—Butt rein-
forced at joints
with steel bush-
ings and having
pin-hole inter-
lined with steel



through the door, about $\frac{1}{4}$ in. of wood being left. This is called the "relish," from an old French word meaning "what is left."

Now refer to the sketch. Thickness of door in closed position $1\frac{3}{4}$ in., plus thickness of door in open position $1\frac{3}{4}$ in., plus thickness of trim $1\frac{3}{8}$ in., equals $4\frac{7}{8}$ in. From this deduct the "relish" of the door in both positions, or $\frac{1}{2}$ in., which leaves $4\frac{3}{8}$ in., the exact width of the butt required to hang the door so it will open back flat against the wall without striking the trim. As butts for large doors are made in sizes varying by half inches it will be necessary to use the size next larger than $4\frac{3}{8}$ in., or $4\frac{1}{2}$ in. wide, and as butts are usually used in square sizes a $4\frac{1}{2}$ by $4\frac{1}{2}$ in. butt should be used. From the above you can make the simple rule of twice the thickness of the door plus the thickness of the trim and deduct $\frac{1}{2}$ for the relish— $1\frac{3}{4} + 1\frac{3}{4} + 1\frac{3}{8} - \frac{1}{2} = 4\frac{3}{8}$ —and then use the next larger width, or $4\frac{1}{2}$ in. In some cases the trim is built up with a wide "back-band" or a heavy "plinth" block; in such cases an extra wide butt must be used. At the same time it need not necessarily be extra high—such as 4 in. by 5 in. or 4 in. by 6 in. These odd sizes are usually made only in butts of high quality. Select only such sizes as are advertised by the manufacturer whose butts you are using.

In the sketch (Fig. 85) you will note an unusual little molding which extends beyond the thickness of the stile of the door. The amount that this projects beyond the stile must be added to the thickness of the trim in order to make sure you use a large enough butt so the molding will not strike against the trim when the door is opened 180 deg. When doors are unusually wide or heavy for their thickness a size larger butt than this rule requires may be used to advantage.

The preceding paragraphs in detail related especially to butts for passage doors. In reviewing it it develops that no mention was made of an important point regarding the loose pin. As a door is opened and closed the pin is inclined to work up—sometimes to considerable extent. This is unsightly and is not good for the wear of the butt. It is caused by the pin binding slightly and turning in one direction only as the door is opened and closed—to overcome this the pin should be so made that it must turn back and forth with the butt (Fig. 86), then it will not rise. Butts so made are said to have "non-rising" pins.

Another way is to arrange a spring ring in the knuckle of the butt (Fig. 87), to slightly bind the pin in its proper position so that it cannot be withdrawn without a slight pull. These are known as "self retaining" pins.

"Self-Locking" Pins

At times butts are made to order so the pins cannot be withdrawn when the door is closed—these are known as "self-locking" pins.

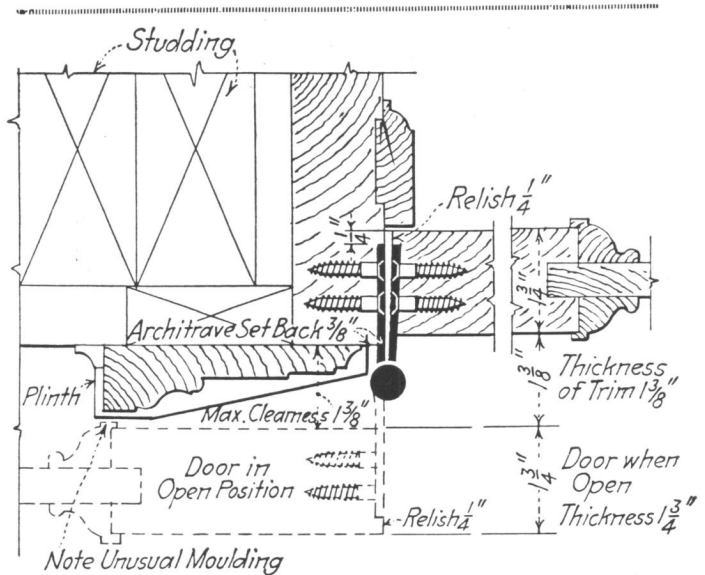


Fig. 85—Detail drawing showing how to determine proper size butt for a door

such butts would be particularly desirable for doors opening out where the butts and pins could be tampered with from the outside. In fact, it is quite possible in such cases to remove the pins, if they are "loose pin" and not "self-locking," and to open the door from the hinge side, especially if it does not fit tightly. Ordinarily such doors and windows are hung on "fast joint" butts. These are not as expensive as the "self-locking" pin type, are quite as effective and easier to get.

Doors for the cupboard and dresser, and other small interior doors are usually light and may be hung with butts of a lighter type than those used for passage doors—loose-pin butts are most convenient. As the doors are usually thin it is common to use butts higher than they are wide—such as 3 by $2\frac{1}{2}$ in. or $2\frac{1}{2}$ by 2 in.—according to the thickness of the doors. A casement sash opening out and having the butts exposed at all times to the weather

should be hung on all brass butts with brass fast pins—or where expense should be considered, a galvanized butt with a brass fast pin makes a good job. Either way avoids the butts becoming rusted so that the sash cannot be easily opened. These butts are usually painted with the sash. Outside hinged window screens may be hung with galvanized butts having brass loose-pins—this makes it easy to remove them for winter.

"Loose Joint" Butts

When transoms are hinged the butts stand horizontally, should have fast pin, and usually have button tips (Fig. 88).

At one time many butts were made with the knuckle divided into only two sections (Fig. 89). The top section onto the flap that was to be screwed to the door and the

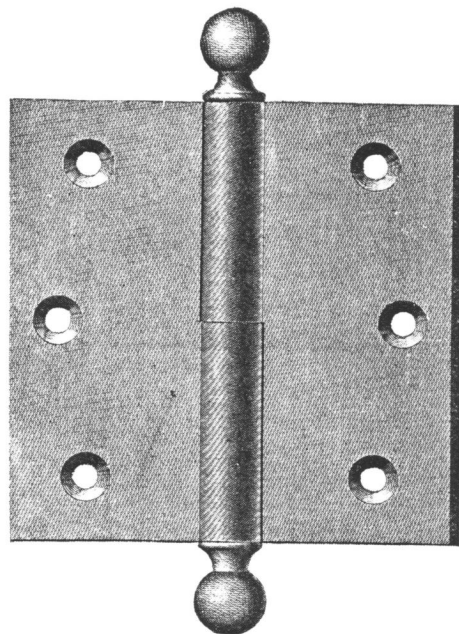
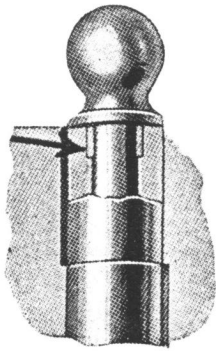
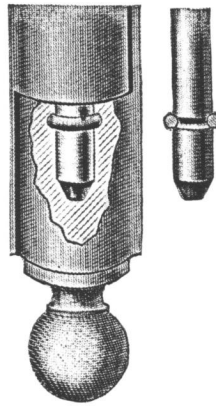


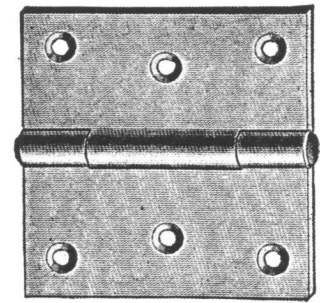
Fig. 89—Butt having knuckle divided in two sections known as loose joint butt



At left—Fig. 86
— Non - rising
pin. At right—
Fig. 87—Self re-
taining pin



At right—Fig.
88—Example of
transom butt
with fast pin
and button tips



bottom section onto the flap to be screwed to the jamb. The bottom section contains the pin. Such butts are known as "loose joint" butts. They are either right hand or left hand, but are not reversible. To determine the "hand" of such butts, hold the section containing the pin, with the pin up, in your hand with the knuckle from you and the back of the flap against your fingers. If you can meet this condition with your right hand it is a "right hand" butt. If you must hold it in your left hand then it is a "left hand" butt. The use of "loose joint" butts is now confined largely to French pattern butts (Fig. 90).

There are special cases where doors are very heavy when it is an advantage to hang them on "ballbearing pivot hinges" as is shown in Fig. 91. These have a heavy ball-bearing pivot built into a metal case that is set into the sill or threshold, and a smaller pivot set into the jamb over the door. This manner of hanging heavy doors insures against the butts pulling away from the jamb thereby allowing the door to sag and bind on the threshold, but there is nothing

to prevent the door from warping and binding, as there is where it is hung with three strong butts.

"Spring" Butts

Butts are made with a spring in the knuckle which winds as the door opens, and when released the unwinding of the spring automatically closes the door. Butts so made are called "spring butts." They are made for doors opening only in one direction and are then "single acting spring butts" (Fig. 92). When they are for doors opening in either direction they are "double acting spring butts" as shown in Fig. 93. The "single acting" type is not much used at present, save for light doors, because it is more satisfactory to hang the door on butts and control its closing with a door closing device (will speak of these later). Double acting doors are now more frequently hung with a spring hinge of the pivot type. For light doors, the sort that are cut into the heel of the door and rest on the top of the floor (See Fig. 94), seem to give very satisfactory results and have the additional advantage of being rather inexpensive. There is another type of double acting spring hinge which has the spring inclosed in a heavy cast iron case that is set into the floor. The size of this case permits the use of a longer and more efficient spring (Fig. 95). This type of hinge costs more than the one described above—it also costs more to apply, but for any but rather light doors, I think the extra expense is justified by the results obtained.

"Checking Floor Spring Hinges"

There is still another style of the pivot type of spring hinge, both single and double acting, known as

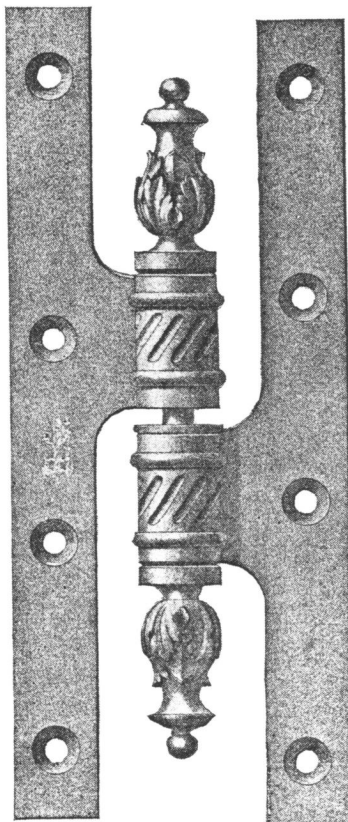


Fig. 90—French
pattern butt of
ornamental de-
sign

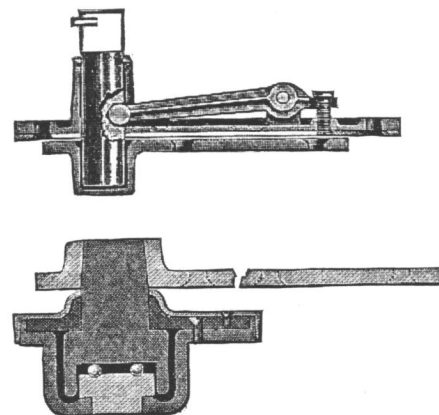


Fig. 91—Ball bearing pivot hinge.
Top pivot shown above, pivot hinge at
bottom

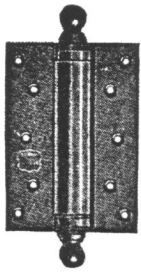


Fig. 92—Single acting spring butt

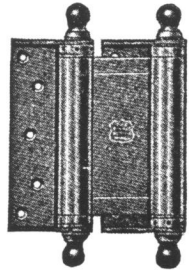


Fig. 93—Double acting

“checking floor spring hinges” (Fig. 96). These have the springs inclosed in a heavy case set into the floor or threshold.

In addition to the springs there is in the case, a liquid controlled checking device by means of which the action of the door may be regulated to suit the individual condition. This is particularly desirable in the case of double acting doors, which, if hung on double acting spring hinges without the checking device, are apt to swing shut very abruptly and flap back and forth several times before coming to a dead stop in the center. Checking floor hinges are rather expensive and are not usually considered except on high-grade work. The work performed by the single acting type can be satisfactorily done by hanging the door on suitable butts and regulating the action by an overhead liquid door closing device.

Hanging Screen Doors

Ordinary cheap screen doors may well be hung on the regular spring hinges made in many styles of the purpose—one style known as a “hold back spring hinge” is constructed so as to hold the door open after it passes a certain point—usually about 100 deg. The better grade of screen doors should be hung on three suitable butts and controlled by a door closing device that will close the door quickly but at the same time prevent the extreme annoyance of slamming.

Invisible Hinges

It is desirable in certain cases to hang doors so that the hinges are not in sight when the door is closed, and at the same time allow the door to open as much as 180 deg.

This is especially desirable for light doors in fine

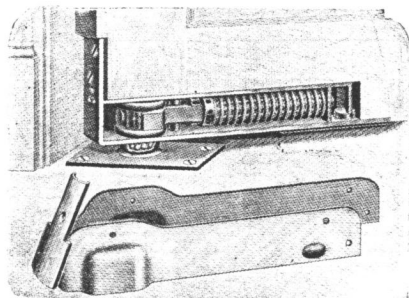


Fig. 94—Surface floor spring hinges

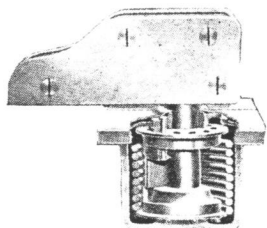
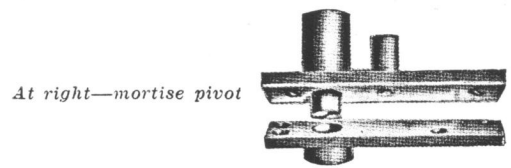
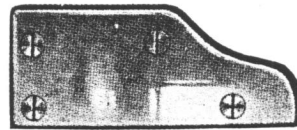


Fig. 95—Another type of floor spring hinge



At right—mortise pivot



At left—side plates

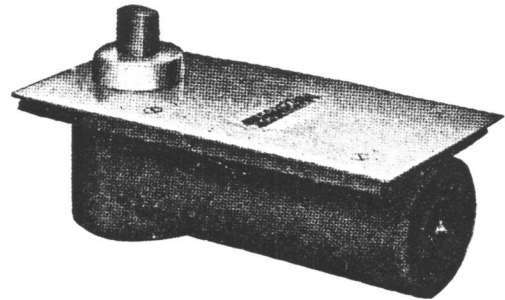
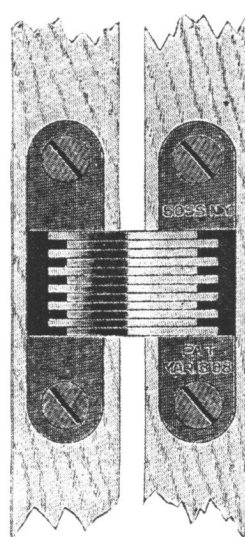


Fig. 96—Checking floor hinges

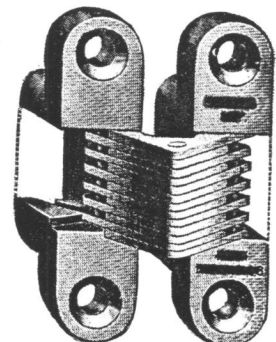
cabinet work and sometimes for heavier doors when it is desired to have the hardware as inconspicuous as possible. So far as I know, there is but one kind of hinge on the market made for this particular purpose—the Soss invisible hinge (Fig. 97). These hinges are very well made and are well suited to the work for which they are designed.

There are a number of styles of butts and hinges made having special features of more or less merit, but for the beginner it is better to stick to regular standard goods of all kinds until his experience develops a judgment sufficient to enable him to properly estimate the lasting value of special devices. There is always a tendency for the beginner in any line of study to push ahead before he thoroughly masters the fundamental steps. Nothing is more disastrous to real mastery of a subject. It is like attempting to build a house on a foundation of sand.



Another view of the invisible hinge

Fig. 97—Example of the invisible hinge used for fine cabinet work when it is desired to have the hardware inconspicuous



CHAPTER V.

The Principal Features of Door Closers

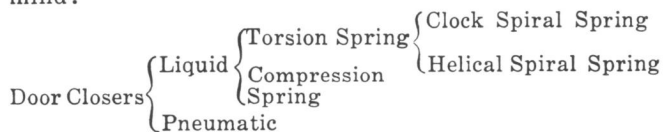
AFTER a door is properly hung on butts of suitable size, weight, and quality, and equipped with a good lock having the functions required for convenience, it is oft-times desirable—yes, necessary, to have its closing under control, as a door constantly open is only a hole in the wall and a door continually banging when it is closed is a source of great annoyance.

Certain doors should always be closed when not being used, while others should be kept closed except when particularly desired to remain open.

Many Door Closing Devices

There are many door closing devices. The simplest is probably the ordinary coil door spring (Fig. 98a). This closes a door surely enough if one does not mind the noise and jar of the slamming each time it closes. For anything but rough work this form of door closer is unsatisfactory. While a door should be closed quickly at the same time, it must be brought silently to its closed position. A number of devices are made to accomplish this end—sometimes known as a “check and spring,” a “door controller,” or a “door closer”—the name “door closer” is probably the most commonly accepted. There are two general classes—“liquid door closers” and “pneumatic door closers”—their names being derived from the means used to prevent the slamming of the door. The closing is accomplished in both classes by means of a steel spring.

The “liquid” class is divided into two sub-classes—one using a “torsion or winding spring” and one using a “compression spring.” The “torsion” class is again divided into two sub-classes—one using a “clock” spring and one using a “helical” spring. The following chart will help fix these various classes in your mind:



Since the “liquid” class is the more largely used it should have first consideration. Both “liquid” types have the closing device or spring and the controlling or checking device combined in a unit. The “torsion” spring type has the spring in a separate chamber or compartment arranged so that it “winds up” as the door is opened and as soon as the door is released the spring unwinds thereby closing the door. The “torsion” springs are of two kinds, one being a broad steel band coiled in the manner of a clock spring (Fig. 98). It is from 1 in. to 2¼ in. in width and from 36 in. to 65 in. in length according to the size of the closer. This type of spring has been used, for this purpose, for many years with excellent satisfaction. The “helical spiral” spring more recently brought into use for this purpose is made of flattened

steel wire wound into a rather large helical spiral (Fig. 99). These vary in length from 75 in. to 240 in., according to the size of the closer. The chief advantage of this over the “clock” spring is that it may be longer and therefore more elastic and admits of finer degrees of tension adjustment (Figs. 100 and 101).

In both the “torsion” spring types the controlling or checking device is inclosed in a chamber separated from the spring chamber and consists of a piston or plunger moving back and forth as the door is opened or closed. This chamber is filled with a non-freezing lubricating liquid.

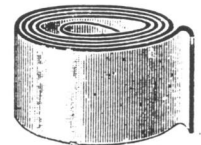
The winding of the spring and the movement of the plunger are accomplished by means of a shaft passing from the top to the bottom of the closer and connected with the spring in the spring chamber and with the plunger in the plunger chamber. In the best constructed closers this shaft has a step bearing at the bottom to help keep it in alignment, thereby reducing the working stress thus minimizing the natural tendency of the liquid to be carried up the shaft by capillary action into the spring chamber through the packing separating the two chambers, which, if it occurs, impairs the checking action of the closer.

How It Works

The shaft is turned as the door is in action by a jointed arm at the top. When the door is closed the spring is very nearly unwound, retaining just enough tension to hold the door closed against a draft. The plunger is at rest in one end of the plunger chamber. As the door is opened the spring is wound and the plunger is drawn back. The liquid that is behind the plunger passes through a small hole in it to the front of the plunger.



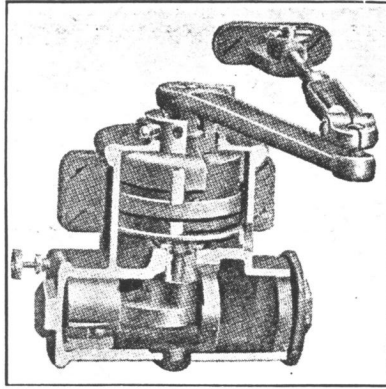
At left—
(Fig. 98A)
Coil door spring



Upper right—
(Fig. 98)
Clock spiral
spring



Lower right—
(Fig. 99)
Helical spiral
spring



(Fig. 100)
Liquid torsion
clock spring
door closer

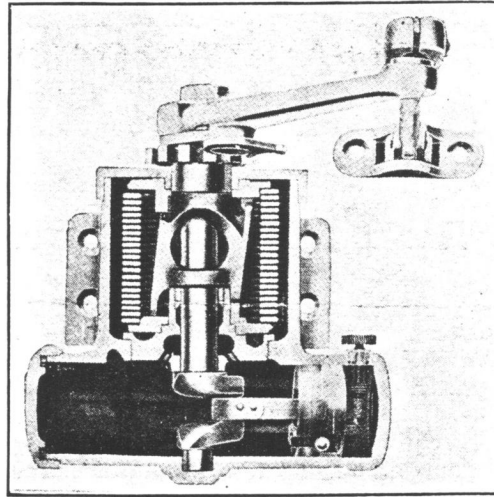
As the door closes the small hole through which the liquid passed is automatically closed by a ball valve thus confining the liquid ahead of the plunger and tending to stop its progress. There is a small by-pass through which the liquid is forced around back of the plunger. The rapidity of the flow of the liquid through this by-pass is controlled by an adjusting screw. When it is open the liquid flows freely, there being no resistance to the plunger and the spring closes the door with a bang. By screwing down the adjusting screw the flow of liquid is reduced which increases the resistance to the plunger and the door is brought silently to its closed position. If the closer is regulated so that the plunger reaches the end of its course before the door is closed there is no more resistance and the door closes with a little jump or slam. This is desirable if it closes against an electric door opener or stiff spring latch bolt, but the action will not be silent. When the plunger still has a little distance to go before the door is closed it may be so regulated that the door closes without any noise. This can usually be slightly regulated by the adjustable arm at the top. The directions for applying that are packed with the closer will give the position of the arm for the standard adjustment. This may be slightly varied forward or back until the desired condition is obtained.

The widely varying conditions under which door closers are required to work make it very necessary that a salesman should acquaint himself with all the general features of door closers, and of the particular points of the make he is selling so that he may be in position to intelligently recommend the proper closer for a particular condition and thereby give satisfaction to the user.

Satisfaction Depends on Conditions

The satisfactory working of a closer does not depend entirely on the closer but much depends on the conditions under which it works.

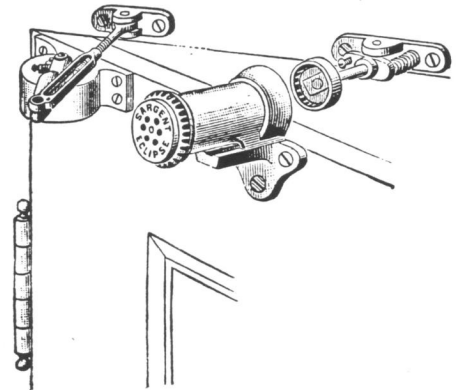
It is very important to see that the door to be closed is properly hung on strong suitable butts—clear and free from all obstructions—does not drag on the threshold nor bind against the hinge jamb, and is not warped nor sprung, but closes easily and evenly into its proper place without force. When



(Fig. 101)
Working parts
of liquid torsion
helical spring
door closer

these conditions are met a door closer has a chance to satisfactorily perform its work.

These closers are made in as many as seven sizes adapted for doors from the lightest to the heaviest. Each maker furnishes a table showing the correct sized closer to be used for the various sizes of standard doors. Study this carefully and do not use an undersized closer. Air pressure and drafts are important factors to be considered. Where these are high, larger closers must be used. You would not wilfully choose a Ford to do the work of a Pierce-



(Fig. 102)
Pneumatic
door closer

Arrow, neither would you choose a Pierce-Arrow for the work for which the Ford is made. Each has its proper and suitable place. Each size of closer is made to satisfactorily accomplish a certain work, and it should not be overloaded.

Most makers give quite explicit directions for applying—some even go so far as to furnish a blueprint template showing the location of every screw. These are carefully prepared and are intended to be followed.

The best closers are made so they may be applied to a right hand door or to a left hand door, or to a door opening in or opening out, without changing any parts.

CHAPTER VI.

Bolts and Door Stops

HAVING supplied doors with butts, locks and door-closing devices suited to the various kinds, it seems quite appropriate now to consider a number of hardware items of lesser importance used in connection with doors. While these items are in themselves simple, yet their proper selection adds much to the convenience and attractive appearance of the doors to which they are applied.

Bolts used in addition to locks probably deserve first attention. When doors are "double" or "a pair" for one opening, it is necessary to supply for one of the doors, usually known as the "standing leaf," a bolt to secure it at the top and at the bottom in order to make this leaf of the pair solid and firm so the other, or "active leaf," which carries the lock, may be closed against it and locked and secured to it.

Foot and Chain Bolts

There are several types of bolts for this use, the oldest and simplest kinds are applied to the surface, and for this reason are the easiest and cheapest to apply. The most commonly known of this sort are the foot bolt for the bottom of the door, and the chain bolt for the top. The foot bolt (Fig. 104) is so called because it is made to be operated by the foot—having a flat place on the top so it may be handily pressed down by the foot and is held in place by a spring. By pushing with the foot against a small button on the front of the bolt the spring is released and the bolt automatically jumps back to its original position. Since the bolt at the top of the door is usually high enough to be out of easy reach of the ordinary person it is made to be operated by means of a chain attached to the bolt, which accounts for the name "chain bolt" (Fig. 105). These bolts are made to operate in much the same manner as the latch bolt of a lock. The bolt is held in position by a spring—as the door is being closed the bolt comes in contact with the strike or keeper, springing back, and then latches into place as the door is fully closed. The chain is for convenience in pulling down the bolt to release the door.

Foot and chain bolts are made of cast iron, steel, brass and bronze and in sizes ranging from 2 in. in

length for light screen or closet doors to 12 or 15 in. in length for heavy garage doors. The "strikes" or "keepers" are made in several forms to meet the conditions at the top and the bottom of the door. Foot and chain bolts are usually strong and serviceable and because of their ease of application are good bolts to use where their appearance is not objectionable.

Another type of bolt used for this purpose is known as a "surface bolt" (Fig. 106) and may be more or less ornamental—it is used in a short length, say 12 in., for the bottom and about 18 in. for the top so the knob may be within easy reach. This type of bolt is made in several sizes or weights to make them suitable for light or heavy doors, or hinged sash.

Still another type of surface bolt, known as a "Cremorne bolt" (Fig. 107), extends the full height of the door, or sash, and is operated by a knob or lever handle, the turning of which throws the bolt into a locked position, or withdraws it at both ends at the same time. The knob or handle is generally placed about 3 ft. 6 in. from the floor. These bolts are usually made of brass or bronze and are used in high-class work, particularly for doors containing a considerable amount of glass. In such doors the stiles are narrow and a bolt applied to the surface does not tend to weaken them as is the case with bolts cut or mortised into the wood. There are many patterns of these bolts, and some of them are quite ornamental. I believe this type of bolt is of French origin. For bolts of this type, in fact all surface bolts, particular attention must be given to the selection of the proper strike or keeper to meet the conditions at top and bottom. Again study the catalog of the maker of the bolts you are selling and you will no doubt find a strike illustrated and described that will be suited to your need.

Flush Bolts

Of the bolts to be mortised or cut into the wood, there are several types, the older one being known as a "flush bolt" (Fig. 108) because it is let into the door flush with the surface. These come in a number of lengths; the bottom bolts need not ordinarily be more than 12 in. in length, sometimes an 8-in. or 9-in.

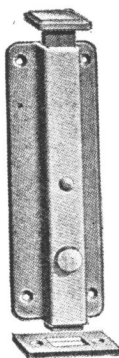


Fig. 104—
Foot bolt

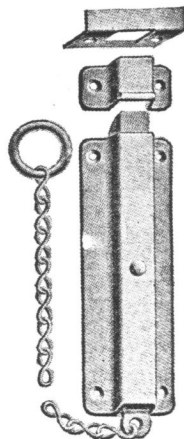
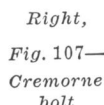


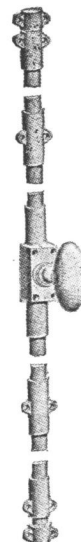
Fig. 105—
Chain bolt

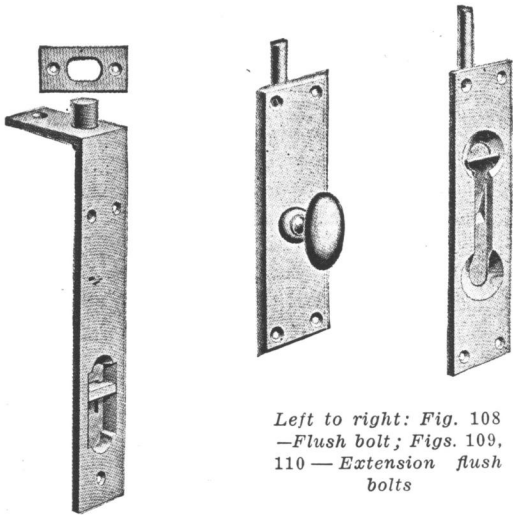


Fig. 106—
Surface bolt



Right,
Fig. 107—
Cremorne
bolt



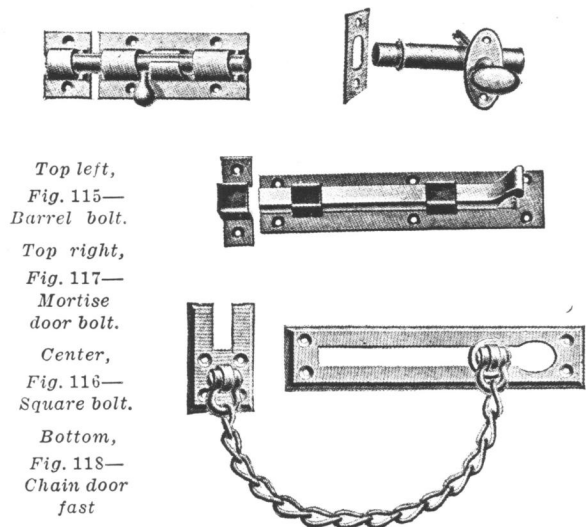


Left to right: Fig. 108—Flush bolt; Figs. 109, 110—Extension flush bolts

bolt may be used, while the top bolt should come down to within easy reach which, in this country, is commonly 18 in., unless the doors are unusually tall, in which case, use a longer one—perhaps 24 in.

Another type of bolt is a modification of the “flush bolt,” and is known as an “extension flush bolt.” The case or working part of these bolts is mortised in flush with the surface of the door, while the rod is bored in from the top or bottom to meet the case and is screwed into it within the wood. In this way it is entirely out of view. The rods for these bolts are of various lengths so that the case may be placed in a convenient position on the door, say 12 in. from the bottom and 18 in. from the top. This type of bolt is made to operate by turning a small knob (Fig. 109) or by means of a lever which lies flat with the case when not being used (Fig. 110). This last is the more popular. It may be placed on the edge of the door if desired, and when so placed cannot be released while both doors are closed. If placed on the edge of a rabbeted door it must be built out with a rabbet strip (Fig. 111) to fit the rabbet of the door; this is usually $\frac{1}{2}$ in.

Still another type of bolt is entirely mortised into



Top left, Fig. 115—Barrel bolt.

Top right, Fig. 117—Mortise door bolt.

Center, Fig. 116—Square bolt.

Bottom, Fig. 118—Chain door fast

the wood and is known as a “mortise extension bolt” (Fig. 112). The center case is cut into the door at the height of the lock and the rods are bored into the door from top and bottom to meet the center case. They are operated in or out by a handle or knob connected with the center case. The face of the center case oftentimes forms the strike for the lock on the other leaf of the door, as shown in Fig. 112.

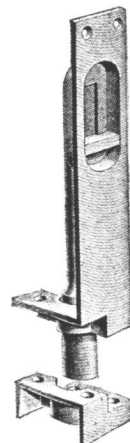
Doors are sometimes cut horizontally across the center, making an upper and a lower part in the manner of a stable door, so the lower part can be shut while the upper remains open. Doors so built are known as “Dutch doors.” For convenience it is often desirable to bolt these two parts together in order that they may be operated as one door. For this purpose “Dutch door bolts” are made. Fig. 113 shows one to be cut into the edge of the door, and Fig. 114 one to be mortised into the side of the door. One seems to be about as effective as the other.

It is sometimes a wise precaution to supplement the security of the lock by a bolt that can be operated only from the inside. For this purpose there are “barrel bolts,” “square bolts,” “mortise bolts” and

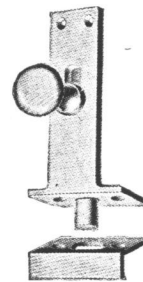


Above, Fig. 111—Extension flush bolt.

Right, Fig. 112—Mortise extension bolt

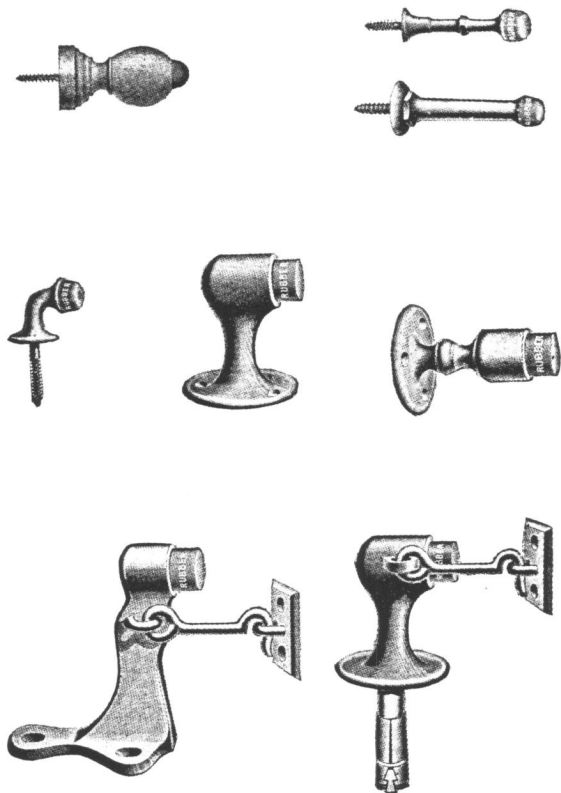


Figs. 113 and 114—Dutch-door flush bolts



"chain door fasts." The barrel bolt (Fig. 115) so named because of its shape, is very simple and effective and its operation is both easy and obvious. It is particularly adapted for outside rear doors of all kinds, for outside cellar doors, and for doors at the head of cellar stairs. Square bolts (Fig. 116), also named because of their shape, are for the same general purpose, but are not so popular. Mortise bolts (Fig. 117) are made for this same purpose and are mortised into the door with only the turn knob showing. These are rather more slightly in appearance than the barrel bolt, but it is not so easy to see that they are "locked," and in that way they are not so convenient as the barrel type.

The "chain door fast" (Fig. 118) is designed more particularly for use on front entrance doors to dwellings so that the door may be slightly opened and still

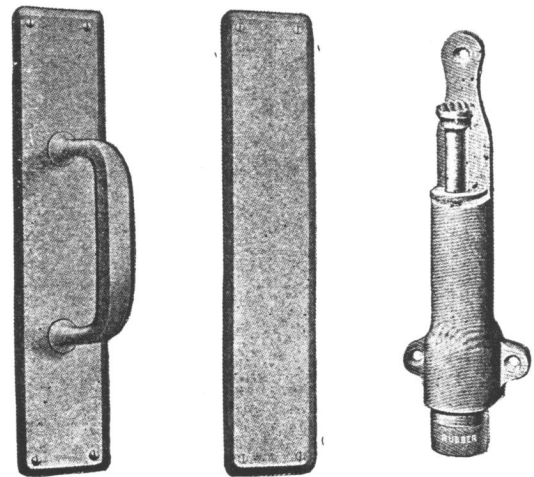


Figs. 119, 120, 121, 122 and 123—Various types of door stops

remain secure against being forced further open from the outside. These are used rather commonly in large cities for extra safety and are made in steel, cast iron, and brass or bronze. The latter is the most desirable, as well as the best looking.

Door Stops and Bumpers

Back of each door there should be placed in the most convenient position a "door stop" or "bumper" for the door to stop against. If the door opens back against the wall the stop may be placed on the base-board so that the door knob will not strike against the wall and break the plaster. If the door should not, for any reason, open back against the wall, then the "stop" may be placed on the floor as much out of the way as possible. Door stops are made of wood, iron, steel and brass or bronze. The wood door stop (Fig. 119) is



Left to right: Fig. 124—Door pull; Fig. 125—Push plate; Fig. 126—Door holder

quite suitable for small houses and may be painted or stained to match the woodwork, which makes it quite inconspicuous yet still serviceable. The iron, steel and brass or bronze ones (Fig. 120) may be in the same finish as the other hardware and in that way attractively show their being and usefulness. If they must be placed in the floor—then one similar to Fig. 121 may be used.

For public buildings, larger and heavier door stops of brass or bronze are made in various shapes (Fig. 122) to adapt them to the places where they must be located. Some are made to be screwed to wood and some with expansion bolts for marble or cement. Others have hooks (Fig. 123) attached for hooking into staples on the doors in order to hold them open. Such doors are usually equipped with door closing devices. Doors of this sort often have a "door pull" (Fig. 124) on one side and a "push plate" (Fig. 125) on the other. These sometimes have the words "Pull" or "Push" cast into them, but most people have sufficient intelligence to know what to do when they see the "door pull" or "push plate" without the "printed instructions for use."

Entrance doors to public buildings may have the lower rail protected against the weather, and against being kicked, by means of a brass or bronze plate

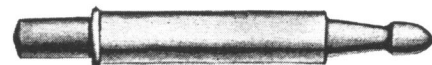
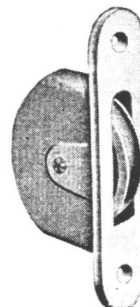


Fig. 127



Left—Fig. 128
Above—Fig. 129

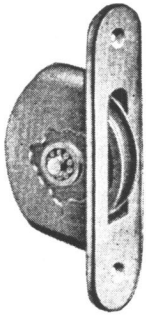


Fig. 130



Fig. 132

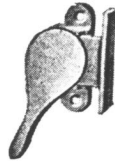


Fig. 133

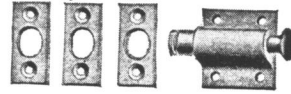


Fig. 134

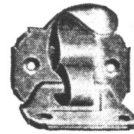
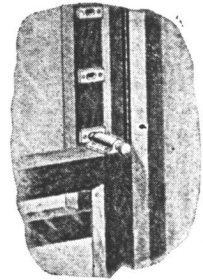


Fig. 135

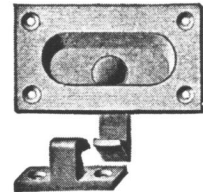


Fig. 136

known as a "kick plate." These vary in thickness, but about 1/16 in. thick is the general average. These should extend entirely across the exposed portion of the rail. They vary in height—8 in., 10 in. or 12 in.—although 10 in. is a good height. The top and two ends are usually beveled slightly as a finish. When these are placed on the inside of a door using an "extension flush bolt" (Fig. 110) the rod should be long enough to allow the case of the bolt to come entirely above the "kick plate" so the plate will not have to be cut around the bolt case.

It is often desirable to have doors which are equipped with spring hinges or any kind of a door-closing device arranged so they may be held in open position when convenience requires. To accomplish this "floor spring hinges" are sometimes made with a "hold open" feature whereby the door may be placed in a certain

position, usually a little more than 90 deg. open, and the hinge will hold it in this position until it is purposely closed.

"Door closers" are sometimes supplied with a "hold open" device to accomplish the same purpose. The position at which the door may be held open is usually 90 deg. or 180 deg.; in some devices this position may be changed from one location to the other to suit conditions. Where the above devices are not available the door may be supplied with a device known as a "door holder." These are made in many forms, to be applied to the surface of the door, and to be operated with one's foot. The type shown in Fig. 126 is probably the most common form. The lower end is of rubber, so it will not mar the floor, and to insure its holding on any kind of surface. They are made in several sizes and in iron, steel, brass or bronze.

CHAPTER VII.

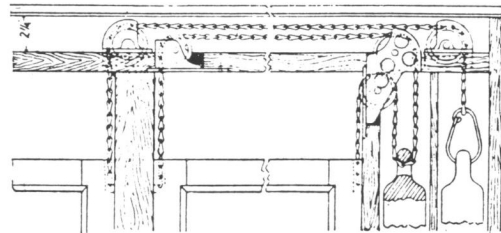
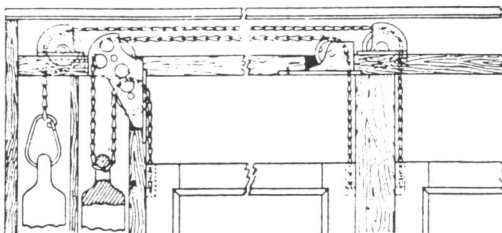
Window Hardware

HARDWARE for doors is usually considered of more consequence than that for windows, and there may be some justification in this for the reason that doors were used in buildings at a much earlier period than windows, and again because doors are more frequently opened and closed. Windows are, however, of much importance in our modern buildings since their sole use is to admit light and air—two most essential elements in our lives. While windows are not opened and closed as often as are doors, it is still very necessary that they operate easily and silently and close tightly. It is for these reasons that they require hardware.

Several Types of Windows

There are several types of windows in general use, the commonest being "double-hung," "casement," "French" and "pivoted"—and the most common of these is the "double hung." This consists of an upper and a lower sash in the same opening, sliding up and down in grooves. In very cheap houses these are held in position by what is known as "window spring bolts" (Fig. 127), a bolt placed in the sides of the sash and having a spring that keeps the bolt thrust through the sash into the side of the groove. This prevents the sash being raised or lowered without first pulling out the "window spring bolts." The sash may then be

Fig. 131



Overhead pulley

adjusted to the desired position, and the bolts released to find their places in small holes that have been bored in the side of the groove.

This is quite an effective way of holding the sash in position, but there is little to be said in its favor when ease of operation and convenience are considered.

"Double Hung" Windows

In all but the cheapest construction "double hung" windows are counterbalanced on weights so that they may be raised and lowered with much ease and so that they will remain in any position without being fastened. The window frames are built with boxes at the sides. At the top on either side a pulley with a grooved wheel is set flush into the frame. These are known as "sash pulleys" (Fig. 128), sometimes "axle pulleys." A cord or chain is fastened to each side of the sash, run over the pulley, and down into the box where it is fastened to a "sash weight." The two weights, one on either side, weigh just as much as the sash after the glass has been put in, thus evenly balancing it. This type of window is very popular and effective. It is the most easily made and is easily kept weather-proof.

The Nature of "Sash Pulleys"

"Sash pulleys" are made with cast iron or steel cases. The cast iron cases are heavier and sturdier and are usually the most satisfactory. The "face" or that part which shows when the pulley is set in place is sometimes left plain iron to be painted with the window frame, the least expensive way. Sometimes it is ground smooth and plated brass or bronze. In the best grade of pulleys, however, it has a sheet of solid brass or bronze the exact size of the face and secured thereto. This overcomes any tendency to rust. The wheels are made of cast iron, brass or bronze, and steel where the cases are of steel. The face is grooved (Fig. 129) to receive the chain or cord—this groove is usually rounded, rather deep, and slightly flattened in the bottom, so it will accommodate equally well either cord or chain. This type is known as the "universal groove."

A few years ago pulleys were made with a different shaped groove for chain than for cord, but the groove described above eliminates the necessity for the two stocks being carried. In the better grade of sash pulleys the wheels are made 2 in., 2¼ in., 2½ in., and 3 in. in diameter. The size to be used depends on the average weight of the sash in the building. The proper size will allow the weight to swing clear in the center of the box and not drag against the sides. The heavier the sash is, the heavier the weight must be and the larger the box must be to accommodate the weight. In less expensive dwellings the 2 in. pulley should be large enough. In better dwellings and public buildings 2¼ and 2½ in. must be used, and for extra large and heavy windows it is sometimes necessary to use the 3 in. wheel, although the 2¼ in. and 2½ in. wheels are most commonly used. They should, however, be large enough so they will run easily and so the cord, if cord be used, will not cut out on the edges of the groove. The wheels run ordinarily on a steel axle, which is frequently made "roller or ball-bearing" (Fig. 130). This adds considerably to the life and easy running of the pulley. When brass or bronze wheels are used, it is strongly recommended that they be roller or ball-bearing to insure their wearing well.

All wheels should have the hub drilled and the groove turned true so that they will run smoothly and evenly.



Fig. 137



Fig. 138



Fig. 139



Fig. 140



Fig. 141

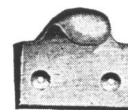


Fig. 142

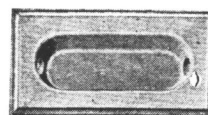


Fig. 143



Fig. 144



Fig. 145

A good, properly turned iron wheel will give good satisfaction—brass and bronze wheels have the advantage of being rust resisting.

Overhead Sash Pulleys

When windows are arranged in groups of two, three or four, with no boxes between them, but with boxes for the sash weights at the sides of the entire group, a kind of sash pulleys is made known as "overhead sash pulleys" (Fig. 131). These are placed over the sashes and arranged in such a way as to carry the cord or chain over to the side boxes. The boxes are made large enough and divided to accommodate the number of weights necessary to balance the number of sash in the group.

There have probably been more different kinds of fasteners for double hung sashes made and put on the market in former years than any other item of hardware, each one having its own peculiar merit, but none of them entirely satisfactory. About twenty years ago there was a sash fastener put on the market by W. & E. T. Fitch and known as the "Fitch sash fastener." It quickly grew into great popularity, because when operated it drew the upper and lower sashes tightly together both laterally and vertically, as it had a double eccentric movement, at the same time being particularly simple in construction. Other manufacturers at once recognized its worth and made it with a modification which in no way sacrificed the desirable features of the original. This type of sash fastener (Fig. 132) has continued to grow in popularity because of its merit—now it is probably more nearly standard throughout the trade than any other item of builders' hardware. The original "Fitch sash fastener" is no longer on the market. They are made of cast iron, brass or bronze and in as many as five sizes ranging from a small size for very light sash in the most modest cottage to a very heavy size suitable for the largest and heaviest windows in public build-

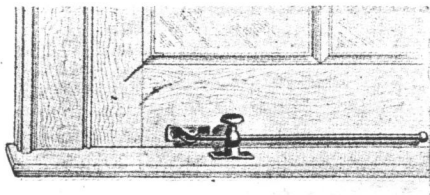


Fig. 146

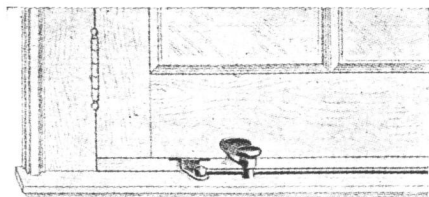


Fig. 147

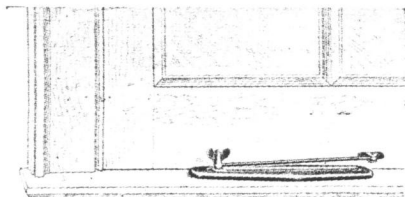


Fig. 148

ings. The middle size is standard for ordinarily good work.

Taking the Rattle Out of Windows

Sashes sometimes fit so loosely, especially in old buildings, that they rattle annoyingly when there is a strong wind. In order to overcome this there is made what is known as a "side sash fastener" (Fig. 133) having a decided eccentric movement. It may be placed on either the sash or on the stop bead. When the small lever is turned it binds the sash in such a way that it cannot rattle. For extra security there is a small "sash bolt" (Fig. 134) made to be placed on the top of the lower sash. The bolt may be projected into a flat strike on the side of the upper sash so that neither sash can be moved from its position. There are usually three strikes with each bolt to be placed in different locations. This allows the sash to be slightly opened at top or bottom; at the same time they cannot be opened beyond the point fixed upon by the location of the strikes.

Windows are occasionally made with but one sash to slide up into a box at the top. To fasten these there is a combined "sash lift and lock" (Fig. 135) made to be placed on the bottom rail of the sash and hook into a strike on the sill. The hook at the top serves to unlock the fastener and at the same time as a lift by which to raise the sash. A somewhat similar device is made to be mortised into the lower rail of the sash (Fig. 136). These are intended for higher grade work but are seldom required and being, in a way, more complicated, it seems good judgment to recommend the simpler rim style shown in Fig. 135.

There is much talk about "burglar proof" sash fasts. Some are more difficult to open or to break from the outside than others, either because of their style of construction or because of their sturdy build, but the idea of any of them being "burglar proof" is not very acceptable. Most any of them will keep out the ordinary sneak thief, but if a real live burglar wants to get in it will be difficult to find a sash fastener that will keep him out. The "standard" style shown (Fig. 132) is the nearest approach to a burglar proof sash fastener of any on the market.

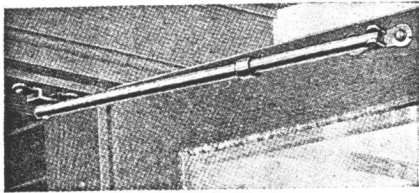
The lower sash of a double hung window is held in its place by strips at the sides, sometimes at top and bottom also. These are known as "sash beads." They should be held in position by screws, as they must be removed if for any reason it is necessary to take out the sash. For this purpose and to more easily adjust them to make the sash fit, there are several styles of "screws and washers" made. Some are simply No. 8 screws 1 in. or 1 1/4 in. in length with a plain washer (Fig. 137). Another type (Fig. 138) has a sunken washer with an elongated hole for the screw. With this kind the stop-bead can be adjusted slightly by loosening the screw a little, which permits the stop bead being moved one way or the other. These are quite convenient. All styles come in iron, brass or bronze, as required. An ordinary window should have four screws on each side and if the head and sill stops are movable they should have three each. As a rule, however, the head and sill stops are secured with nails and are not intended to be movable.

Sash Pull Plates

The upper sash being high and out of convenient reach is often fitted with a plate known as a "sash pull plate" (Fig. 139) with a hole in the center into which a hook on the end of a pole known as a "sash pull hook" (Fig. 140) may be placed to raise or lower the sash. These are very commonly used in public buildings, but not so much so in dwellings. An oak pole

about $1\frac{1}{8}$ in. in diameter of suitable length 4 ft., 5 ft. or 6 ft., according to the height of the window, with sash pull hook attached, is supplied for each room. In order to insure the pole being at hand when needed a "sash pole plate" (Fig. 141) having a suitable hole in it is supplied for each pole and usually fastened in an inconspicuous place on the wood work near the window. The pole is hung into this when not in use.

For convenience in raising the lower sash several styles of "sash lifts" are made to be secured to the lower rail. "Hook sash lifts" (Fig. 142) to be screwed onto the surface; "flush sash lifts" (Fig. 143) of design to match the remainder of the hardware in the building, to be mortised in flush. Some flush sash lifts have a lip on the upper side of the opening to give an extra hold for the fingers (Fig. 144). Then

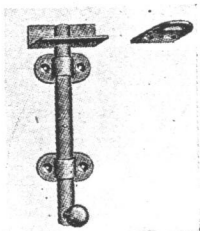


Left—Fig. 149

there are "bar sash lifts" (Fig. 145) of several styles, to be screwed onto the surface. These afford the best hold for the hands if the sash is at all heavy. For narrow sashes one lift is enough, but for medium and wide sashes is customary to use two lifts.

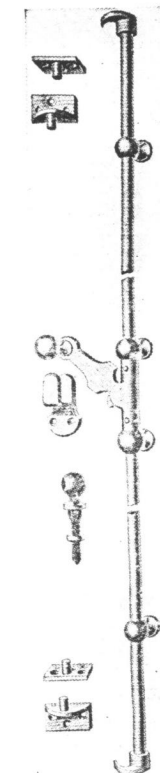
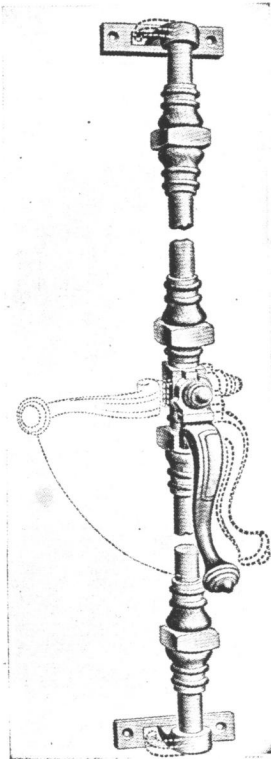
Hardware for other types of windows will be taken up in the next chapter.

The second most common form of windows are known as "casements." These are



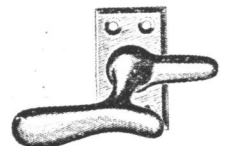
Left—Fig. 150

Right—Fig. 151



Left—Fig. 152

Right—Fig. 153



sash hinged at the side. They may have one sash to the opening known as "single" or they may have two, meeting in the center and known as "pairs." Casement sashes may open in or out. If they are in an unprotected location they should, if possible, open out as it is quite difficult to build them to open in and be weather proof as rain storms are likely to beat in and do damage.

When they open out the butts should be "fast joint" and should be made of brass, but they need not be highly polished. Should brass be too expensive then they should be of galvanized iron or steel with brass

pins so that they will not rust and be difficult to operate. If the sash opens into the house the butts must match the other hardware and they may be "loose-pin." In determining the size to be used, study carefully the natural position the sash will take when open and use a width of butt sufficient to accomplish this. There is no advantage in having the butts wider and more conspicuous than is absolutely necessary.

When the sashes are opened either in or out they should be controlled and held in the desired position, and in order to accomplish this, there are many types of "casement adjusters" made. The most common of them for sashes opening out, is a rod having a hinged foot at one end to be fastened to the sash, and a swivel guide, with a thumb screw for clamping, to be fastened on the sill (Fig. 146). As the sashes are opened the rod slides through the guide and can be clamped in any desired position. For sashes opening in the device is quite similar except that the foot is fastened to the sill and the swivel clamp guide to the sash (Fig. 147). Both of these are made in several weights and lengths in order to be suitable for light or heavy sashes of different widths. The cheaper ones have round rods while the high grade ones usually have square rods. The principal objection to these is that they take too prominent a place on the window sill, but their simplicity and efficiency is much in their favor.

When something slightly less noticeable is wanted the swivel clamp is made to move in a slatted plate placed on the sill (Fig. 148). These are made only for sashes opening out. There is another kind known as a "friction holder or adjuster."

The most popular form is in the way of a tube and rod (Fig. 149). The tube is secured at one end to the sill or soffit of the frame by means of a hinged foot and the rod is similarly secured at one end to the sash while the other end of the rod slides back and forth in the tube. There is a friction device where the rod enters the tube that makes it necessary to use some force to push the rod back and forth in the tube as the sash is opened and closed. The friction is sufficient to hold the sash in this position. In the better holders of this sort, the friction device is adjustable partly to suit the pressure required to move the sash, and partly to take up whatever wear there may be. The style of holder is frequently placed at the top of the sash instead of on the sill, and when so placed has the advantage of being out of sight and out of the way of draperies.

There have been made a number of what are known as "concealed adjusters." These are usually placed under the sill and should have room

Fig. 154

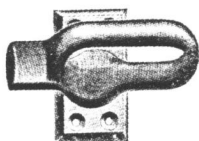


Fig. 157

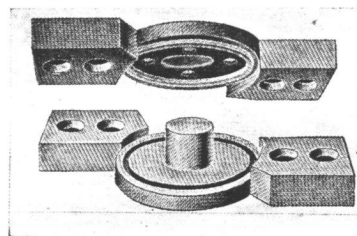
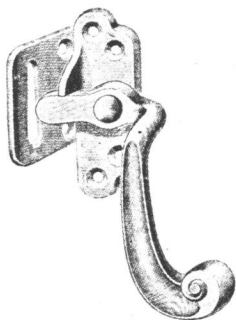
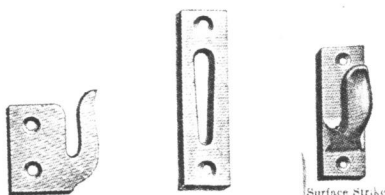


Fig. 155



Below—Fig. 156



provided for them as the house is being built. When the sash is closed the adjuster closes in under the sill out of sight with only the operating handles showing. One of the difficulties encountered with these is that they are apt not to be very rigid and allow the sash to rattle with the wind. Again they are not very easy to apply and are rather expensive, all of which tends to curtail their use.

When casement sashes are in pairs they should be rabbeted where they come together to insure their being weather-proof. The sash closing first should be fitted with a bolt at the top and bottom. As there is not much wood in the sash it is better to use bolts to be applied to the surface such as was shown in Fig. 106, rather than to be cut or mortised into the wood. For light sashes a simpler but lighter one

(Fig. 150) may be used. The top bolt should be long enough to be within reach for operating. For heavy sashes a combined top and bottom bolt, a "Cremorne bolt," shown in Fig. 107, may be used. This bolt may be placed on the last sash closed and thereby eliminate the necessity for any other fastener. Cremorne bolts

are operated by a knob or lever handle placed in a convenient location. The rod from the handle to the top is often longer than that from the handle to the bottom.

There is still another device made for securing casement sashes at both top and bottom—it is known as an "Espagnolette bolt or bar" (Fig. 151). This consists of a long rod, or bar, with hooks at top and bottom so that by turning the bar with the handle the hooks are made to engage in keepers and draw the sash tightly closed. The keepers may be as shown for sashes opening in or they may resemble little posts around which the hooks engage when the sash opens out. The particular style of strike to use depends on the trim at top and bottom. In an "Espagnolette bolt or bar" of the type shown, the bar may be turned when the handle is raised, but is locked when the handle is down. There are simpler styles in which the handle engages in a keeper when in a locked position (Fig. 152). Cremorne bolts and Espagnolette bars may be used on single sashes as well as on pairs of sashes.

There are many styles of "casement fasteners" and as they are all made to serve the same purpose their difference is largely in design or weight. For light casements one something like that shown at Fig.

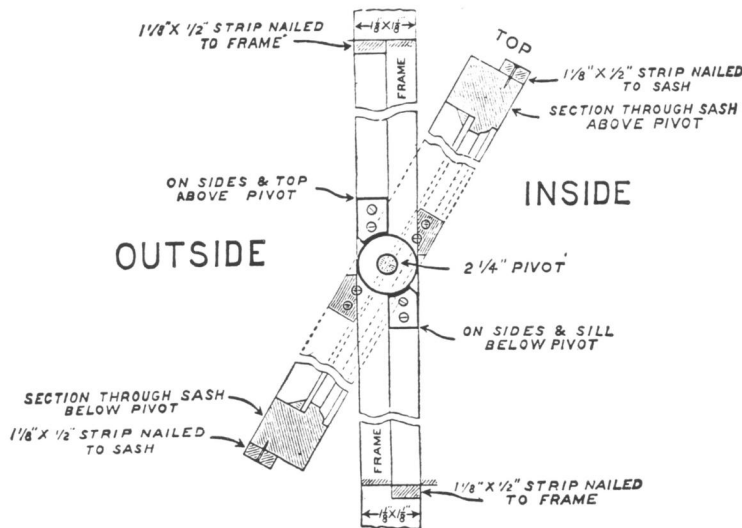


Fig. 159

153 may be used—for heavier sash one like Fig. 154 is good. Fig. 155 shows an English pattern that is both effective and good to look at, but it is "handed"—that is, the same one cannot be used on either a right hand or left hand sash. There are three general styles of keepers or strikes for casement fasteners (Fig. 156) one of which will usually fit. Care must be taken to select the style strike suited to the detail of the sash for which it is intended.

When casement sashes extend to the floor they are usually known as French windows, but are used as doors. They may be hung with the same kind of butts as casement sashes. Since they are used as doors they are usually secured by a narrow stile lock of suitable size, operated by a knob and lever handle. When in

pairs a Cremorne bolt for the sash first closed makes a good job, or they may be fitted with surface bolts at the top and bottom. In order to insure security a surface bolt may be used at the top and bottom of each sash and the bolts on the sash which carries the lock may be "bolted" only at night or such other time when the security is desired. Of course, when so bolted the sash can be opened only from the inside.

Sashes are sometimes "pivoted" at top and bottom or at the sides, so they may be turned on the pivots. This is particularly good for heavy sash as they are balanced and for that reason more easily operated and controlled. Exterior pivoted sashes are usually rabbeted to make them weather proof. For such sashes what is known as a rabbeted pivot (Fig. 157) is used. They are made in iron and brass or bronze. They open and close

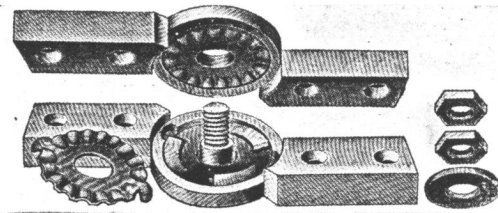


Fig. 158

Sashes over doors and windows are known as "transoms." They may be hinged at the top or at the bottom, or may be pivoted at the ends. They may be operated from the floor by means of a device known as a "transom lifter," which is made with a rod carried down to within 4 ft. of the floor so as to be within easy reach and control. The one designed for a pivoted sash is shown in Fig. 163.

For sashes hinged at the bottom with the top opening in a lifter having the arm hinged above the sash and sliding on a separate rod (Fig. 164) should be used, as with it one has much better control of the transom. It is sometimes desirable to have exterior transoms, hinged at the top and opening out at the bottom. This requires a lifter having the arm made so that it will push the bottom out as the rod is pulled down (Fig. 165). It is very unusual to have sashes hinged at the bottom

and out at the top as this arrangement affords no

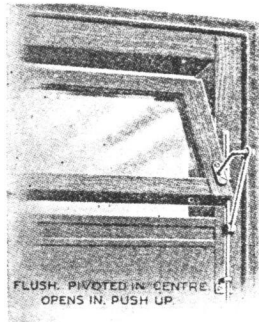


Fig. 163

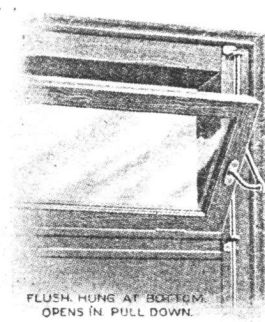


Fig. 164

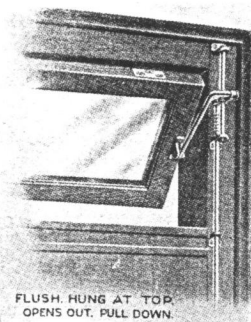


Fig. 165

much the same as do a pair of shears. They are usually 1/2 in. in thickness as that is the thickness of the common rabbet. These pivots must be of the same width as the thickness of the sash. Some pivots of this sort are made with a friction spring washer (Fig. 158) calculated to hold the sash in several different positions when open. The application of a rabbeted sash center is shown at Fig. 159. When sashes are not rabbeted a pivot style (Fig. 160) may be used. Sashes pivoted at top and bottom may use the same adjusters and fasteners as are used on casement sashes. For this type of sash there is a pivot device made with a heavy lever for elevating the sash above the rabbet so that it may be turned. When closed it is let down and becomes weather proof. Interior sashes pivoted at the sides may be hung on pivots with one end open so that the sash may be removed (Fig. 161) or with a surface pivot (Fig. 162). Sash pivots are often known as "sash centers" because they are mounted in the center of the sash.

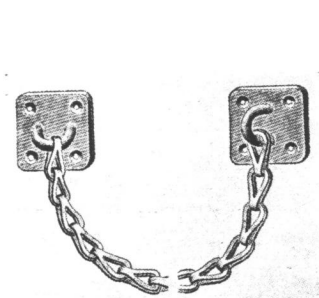


Fig. 166

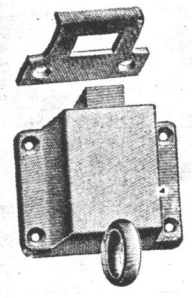
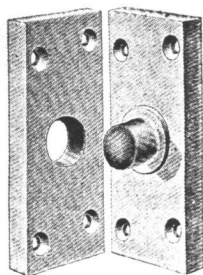
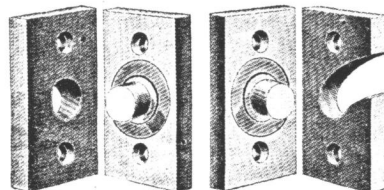


Fig. 167

protection from weather and drafts. When sashes are hinged at the top and open in at the bottom the

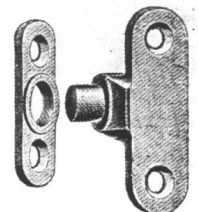


Left—Fig. 160



Left—Fig. 161

Right—Fig. 162



same style of lifter may be used as is used for pivoted sashes (Fig. 163).

All of the above mentioned transom lifters are secured in any position by means of a fastening device near the lower end of the long rod. Usually transoms are hung flush with the inside trim and a lifter as regularly made for stock should work it. If the transom is set in or "recessed," however, an additional length of bracket (the piece that is fastened to the sash) is required. In case there is no place on the trim within about 2 in. of the edge of the sash to place the guides for the lifter, then the bracket must have a greater "offset." The amount of offset depends on the extra distance you will have to set the guides back on the trim. Regular "stock" lifters will operate in most places. The catalog of the maker of the lifters you are using will give you the necessary information to cover the "recess" and "offset" when ordering.

The size of transom lifters is designated by the diameter of the rod $\frac{1}{4}$ in., $\frac{5}{16}$ in. and $\frac{3}{8}$ in. and by

the length of the rod. The small $\frac{1}{4}$ in. rod is intended only for very light transoms. The $\frac{3}{8}$ in. size should be used for all good work. In order to determine the length of the transom lifter required, measure the distance from the floor to the top of the transom and deduct 4 ft. The length of transom lifter varies by full feet, that is 3 ft., 4 ft. or 5 ft., and it is rarely necessary to cut them finer than this.

There are made what are known as "concealed transom lifters"—that is, the working parts are placed under the door casing and are operated by means of a small exposed handle or knob. These are in the same class with concealed casement adjusters, their principal recommendation is that they are not in sight.

Sometimes it is desirable to have the opening of transoms controlled by what is known as a "transom chain" (Fig. 166). These hold the transom open, and when the transom is closed it is secured by a catch (Fig. 167) which may be operated from the floor by means of a sash pole with hook.

CHAPTER VIII.

Hardware for Bath and Toilet Rooms

IN our modern dwellings and public buildings the bathrooms and toilet rooms have grown in importance to such an extent that they are receiving rather outstanding attention from the owners, architects and builders. They have, in fact, come into such prominence that there seems to be a sort of rivalry as to who can have the best appointed, not only in the planning, but in all the fittings to the finest detail. This brings us to the consideration of what is best in hardware for such rooms, what is best in construction, general usefulness and appearance.

Usually these rooms are done either in white or in some light shade with all exposed metal work nickel-plated. Since there is more or less dampness in bathrooms, the metal work should be of brass or bronze to receive the nickel plating, thereby insuring against rusting through as it would if the nickel plating were on steel or iron. So far as the item of hardware is concerned, the expense of using brass or bronze instead of steel or iron should not be seriously considered, as durability and lasting satisfaction are important and cannot be obtained without price. There is another composition of metal suitable for this sort of hardware which will be considered in a later article relating to metals and their finishes.

The Entrance Doors

The entrance doors to bathrooms and toilets in dwellings should have a knob latch with a dead bolt to be operated from the inside by a turn knob instead of a key. It is desirable to have this arranged so that the dead bolt may be opened from the outside by a key in case of an emergency. The inside knob operating the latch bolt may be of metal, but one of plain glass or opal glass, as may be seen in Fig. 168, is better looking, more in keeping with the other fittings as well as more durable in view of the fact that dampness has no effect upon it. The outside knob and escutcheon for all these doors should be of a design and finish to match the hardware in the hall or outer room when the door is closed.

Closets and Medicine Chests

Most bathrooms have a closet and a medicine cabinet. The closet door should have a simple knob lock of good quality with knobs and a small escutcheon to match the entrance door (Fig. 169). In these days many of the medicine closets are of white enameled metal and are equipped by the maker with a lock or catch. If, however, it is built in of wood with a small lock with key and latch bolt to be operated by a small glass knob

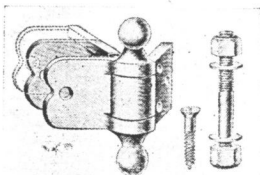


Fig. 171
Right—Fig. 172

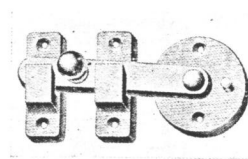
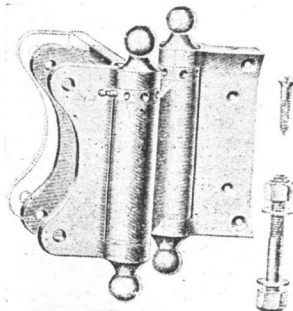


Fig. 173

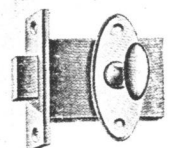
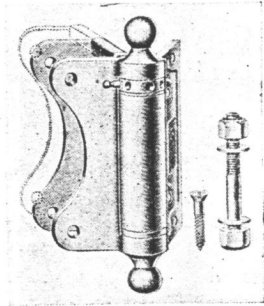
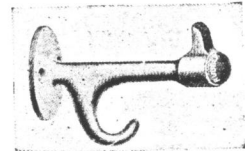
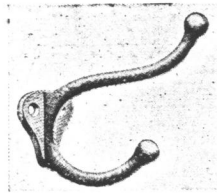


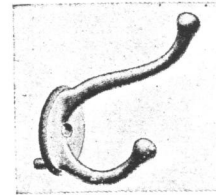
Fig. 174



Upper left to right—Figs. 168 and 169. Left—Fig. 170



Upper left to right—Figs. 179 and 180. Right—Fig. 181



matching, of course the large knob should be supplied. The windows of a bathroom will require the same sort of hardware as any other room in the house, but it should all harmonize in simple design and finish with the door hardware.

Bathroom fixtures, such as towel rods, soap dish, sponge rack and paper holders, are often not thought of as a part of the "hardware," but they are quite necessary and may well be considered as an important item for the complete fitting out of the new bathroom and toilet. It is a line of considerable assortment and should be made profitable. Effort should be exerted toward selling substantial articles of good quality. Most of this line is made of heavily nickel-plated brass. However, there are towel rods of plain and opal glass and quite a complete line of articles made in heavy white porcelain enamel. When the home-builder is considering the door and window hardware for the new bathroom his mind will no doubt be receptive to the suggestion that the job be completed by selecting the proper fixtures to put on the final finishing touch.

Toilet Room Hardware

The doors of toilet rooms in public buildings should be supplied with cylinder locks having key arrangements suited to the control desired. Sometimes the entrance doors to such rooms are not kept locked, but there are conditions where it is desirable that only the tenants of such buildings should have access, and in either case a lock having stops in the face to set the

outside knob when required will usually be satisfactory. If the outside knob is set by the stop, entrance must be had by the key, or the stop may be "left off," and free access may be had by the knob—the inside knob operating the lock at all times.

As these doors get considerable use, the knobs and escutcheons are better when they are made of brass or bronze of strong construction but simple design.

The small toilet compartments partitioned off by wood or marble are usually called water closet stalls, although in at least one of our large cities they are often referred to as "cubicles"—from the word "cub"—meaning small. The doors to these small enclosures are commonly hung with spring hinges about 4 in. high, either to open in or to open out. Usually these hinges have the spring wound to the right which serves to close the door after it has been opened, but sometimes they are made with the spring wound to the left, or "reverse spring," so that the door will remain open. In this arrangement the doors open into the stall.

Hanging Doors to Marble

When these compartments are partitioned off with marble the doors must be hung to the marble and hinges especially made for this purpose, such as Fig. 170, must be used. They are made with the regular flap to be secured to the wood of the door. The flap for the marble is made to clamp around the edge of the marble and is secured in position by bolts passing through the marble as well as the metal on each side.

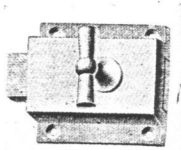


Fig. 175



Fig. 176

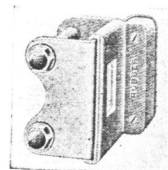
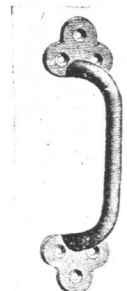


Fig. 177
Right—Fig. 178



The marble to which the doors are hung is usually about $1\frac{1}{8}$ in. in thickness, but often varies considerably from this so that the "clamp flap" is made that it may be adjusted to several thicknesses. If it were not for this adjustment it would be rather impracticable to carry the hinges in stock.

For economy's sake sometimes one small "blank" hinge (Fig. 171), that is one without the spring, and one spring hinge (Fig. 170) is used. If the door is very light this may give a degree of satisfaction, but do not recommend this sort of economy unless you actually know that the doors are light. It usually requires the full pair of spring hinges to give lasting satisfaction. If it is desired to have the doors "double acting" (open in or out) hinges with a spring in each knuckle (Fig. 172) must be used. If the partitions are of wood, then the hinges and fasteners need not be of the "clamp" sort, but can be made to simply screw to the wood.

There are several fastenings for doors of this sort. The simplest is what is known as a "throw over" latch (Fig. 173). This is simple in construction and is very effective and easy to apply, all of which serve to recommend it. Then there is a mortise bolt (Fig. 174) which is turned by means of a small knob on the inside. The same general sort of bolt is made in rim form to be screwed to the surface of the door (Fig. 175). Both of these bolts may be had with or without an indicator (Fig. 176) which turns with the action of the bolts and shows whether the stall is occupied. This is a very convenient device.

The keeper or strike of each of the above is made to clamp to the edge of the marble in the same manner as the hinge (Fig. 177). The part against which the door strikes is covered with heavy rubber in order to kill the slam of the door. These strikes must have the proper opening, loop or hook to receive the particular fastener you have selected to use. It requires careful attention to the catalog description in order to be sure that the proper combination of fastener and strike is selected to meet the requirements of the door arrangement.

For stall doors opening out a suitable door pull, such as is shown in Fig. 178, should be supplied for the outside of the door.

Clothes Hooks Needed

Bath and toilet rooms should have a liberal supply of good clothes hooks (Fig. 179) and at least one should be furnished for each stall. This may have a rubber in the long hook (Fig. 180) so that it may be screwed on the inside of the door, the rubber to take the slam if the door is pushed back against the marble. If the hook is to be secured to the marble, then one must be selected that is made so that it can be put on with a bolt through the marble. Fig. 181 is a good example of this type.

The metal work used in setting the marble, such as clamps, legs and rods, is usually furnished by the contractor who does the marble work and is not commonly considered as a part of the hardware. All doors to toilet rooms should be supplied with a door closer of suitable size and these may be had in aluminum—bronzed or white enamel finish.

CHAPTER IX.

Rough Hardware and Contractors' Supplies

THE term "builders' hardware" usually brings to one's mind the locks, knobs, escutcheons, sash locks, lifts and bolts required for homes and public buildings. These items are builder's hardware, true enough, although they may be more particularly classed as "finishing hardware." There are, however, a number of equally important, though less attractive, items included under the general term builders hardware, but commonly referred to as "rough hardware." This class includes quite a large number of hardware items used in the construction of a building rather than in the finishing of the interior. These items separately do not amount to any large sum of money, but taken as a whole they afford an opportunity for considerable profit.

They have an additional attractive side in that they rarely ever require any attention or concern after being delivered to the building. Again, they are quite often the opening through which the sale of the finishing hardware is made. The need for certain of these items appears as soon as the contractor stakes out the building and continues, item after item, through its entire construction until its completion and the landscape gardener has finished his planting.

Types of "Rough Hardware" Used

As the cellar walls of a dwelling progress a modern combined window and coal chute, such as is seen in Fig. 182, should be provided. These are made of cast iron or of steel, have solid iron or steel doors, or

doors with wire glass to admit light. They are fitted with opening, closing and automatic locking devices which make them a great convenience.

It is not uncommon in good dwellings to have all the basement windows of steel frames and sash as in Fig. 183. Most of them are made with fixtures for opening, closing and fastening, and are furnished in complete units ready to set in the wall. They are made in several suitable sizes and are usually fitted with wire glass which eliminates the annoyance of the too often broken cellar windows. These are stronger and more nearly burglar proof than the usual wood windows and the prices are not unreasonable.

The chimneys for the several fireplaces should each have a cast iron clean out door and frame on the level of the cellar floor for the removal of the ashes coming from above, and each fireplace should have an iron ash trap, and a cast iron chimney throat and damper such as is shown in Fig. 184.

Building Papers Needed

If it is a brick building tie irons and toggle bolts for holding the door and window frames into the wall will be required, if it is a frame building, sheathing paper of good quality will be required between the sheathing and siding, and whether brick or frame, good roofing paper must be supplied for under the final roof covering, what ever it may be. Deadening felt paper will be required over the rough flooring before the finished floor is laid, all of which is carried under the general term of "building papers." There

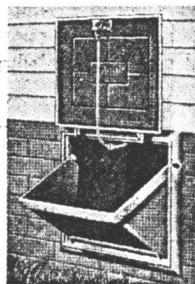
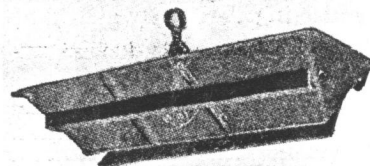
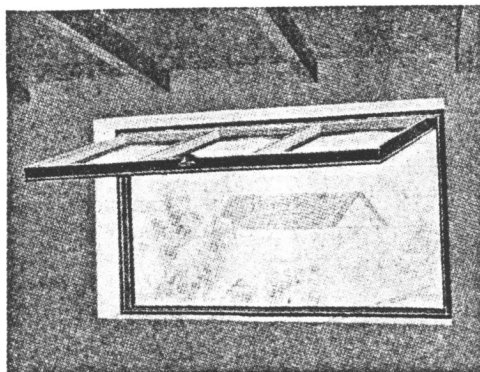


Fig. 182—Iron coal chute



Left, Fig. 183—Steel basement window

Above, Fig. 184—Fireplace damper and throat

are various kinds and grades, but it is always best to try to sell goods of lasting quality.

Of course, there are always nails of various kinds, as well as screws and bolts required as the building progresses.

Sliding doors are not as commonly used in dwellings as they at one time were—still they are frequently put in. Churches and schools often have quite an elaborate arrangement of sliding doors between class rooms. Garage entrance doors are sometimes most convenient when they slide. All these should be supplied with first-class, sliding door hangers of the type intended for the door to be hung. They should have roller or ball bearings and be strong and heavy enough to carry the door. The tubular type of track, either square or round, is probably the most popular as it eliminates the possibility of the hanger getting off the track. There are a number of makes of sliding door hangers and track, each having its particular merit. Whatever you do, select a standard make with a sufficient assortment to meet all regular requirements, and then study carefully the firm's catalog in order to thoroughly familiarize yourself with all their details so that you will be in position to advise the proper hanger and track for your customers to use.

As the joists are being placed hangers will be required for carrying the ends of certain joists and beams around openings and elsewhere. These, as are shown in Fig. 185, are made of malleable iron and wrought steel. They come in a variety of sizes to accommodate the thickness and width of the joist, and for fastening to wood or iron beams, and for building

into brick walls. In close association with these there are cast iron or wrought steel post caps and bases for use where posts and cross beams meet—these are made in sizes required by the posts and beams.

Sash weights are quite important items of "builder's rough hardware." In different localities they present different problems. If you are fortunate enough to be located where sash weights are made, some of the problems, such as freight and hauling, both of considerable moment because of the tonnage, are eliminated to a great extent. If you are not so located your selection of source of supply and style of weight must receive particular attention. Weights are made of cast iron or cast lead. The iron weights are made round, square, and in sections of various types. They are all made in a large range of sizes in order to take care of the large number of sizes of sash. Ordinarily most requirements can be supplied from the regular stock sizes, but there are times when the size and shape of the sash and of the boxes make it necessary to have special weights cast so enough pounds to balance the sash can be put into the box. Low windows that are very wide and heavy require short weights of large diameter. When the weights must be large and the boxes are small it is sometimes necessary to use lead weights.

Lead weighs 1.45 times as much as iron and since cast iron sash weights are very porous they will probably not weigh more than 60 per cent as much as lead weights. The square weights have an advantage over round weights in that more pounds to a given length can be put into the square box. Sectional weights are

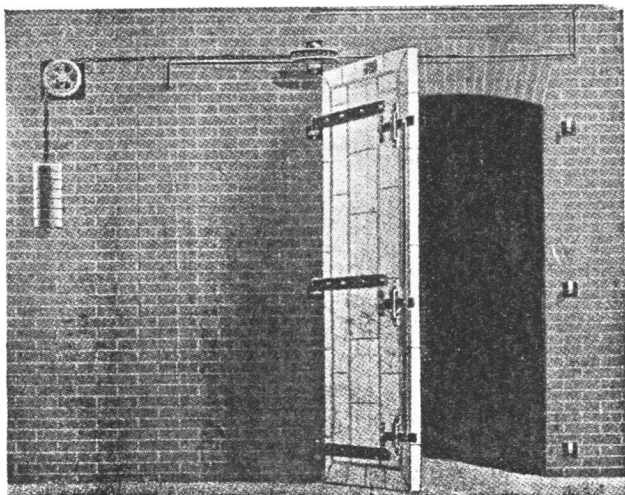


Fig. 186—Automatic swinging fire door

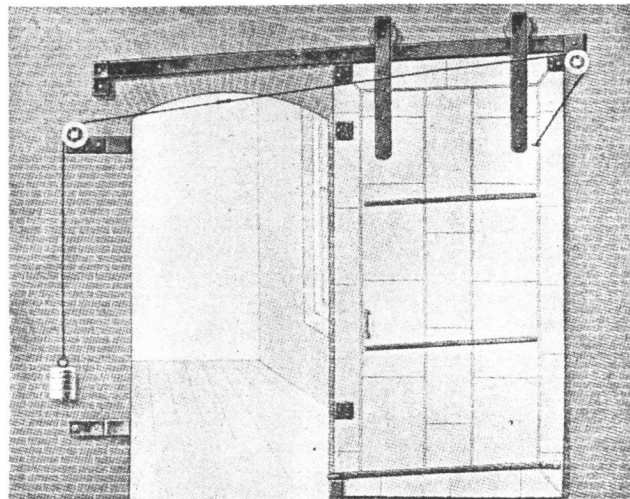


Fig. 187—Automatic sliding fire door

made in small units which fasten together and in that way can be built into as many pounds as required.

If the opening through which the weight is put into the box—known as the “pocket”—is short you may have trouble to get the required size of regular cast iron weights into the box, in which case you may have to resort to sectional weights or even lead weights.

To determine the size weights required for any given sash the carpenter usually weighs the sash with a scale after the glass is set, but it is often desirable to estimate in advance the number of pounds of weights required for a building—this is not a task to be approached too lightly as it affords an excellent opportunity to lose money if not properly done. The thickness of the glass and the thickness and kind of wood of which the sash is made are all elements to be considered. Glass used in cheap construction is usually known as “double-thick.” For better work plate glass is used; this is thicker and therefore heavier than “double-thick.” There are two general thicknesses of plate glass, $\frac{3}{8}$ -in. and $\frac{1}{4}$ -in., but in neither case is it of uniform thickness, that is, it varies somewhat from the $\frac{3}{8}$ or $\frac{1}{4}$ -in., which makes the weight vary.

A Rule for Estimating

The following rule is used in general estimating by a number of good builder's hardware men. Compute the number of square feet in the various windows by getting the height and width from the blueprints for the building. Get this as carefully as possible. If the sash is of white pine and is $1\frac{3}{4}$ in. thick, and glazed with double-thick glass, multiply the number of square feet in the window by $2\frac{1}{4}$; the result is the number of pounds of weight required to balance them.

If $\frac{1}{8}$ -in. plate glass, or one of the fancy types such as “Florentine” or “chipped” is used, then multiply the number of square feet by $2\frac{1}{2}$.

If $\frac{1}{4}$ -in. plate glass is used, then multiply the number of square feet by $4\frac{1}{2}$ and you have the number of pounds.

For example, a window 3 ft. wide and 6 ft. high contains 18 sq. ft. of surface, this multiplied by $2\frac{1}{4}$ gives $40\frac{1}{2}$ —the number of pounds for “double-thick.” And 18 multiplied by $4\frac{1}{2}$ gives 81 pounds for $\frac{1}{4}$ -in. plate glass.

How to Figure Wire Glass

Wire glass, which is plate glass cast with a wire mesh in it to prevent its falling apart if cracked, is made polished or rough. If polished it weighs about the same as $\frac{1}{4}$ -in. plate—if rough it will likely weigh a little more because it has not been ground down smooth. In beginning to estimate the number of pounds of weights required, take a small job and try it, and then keep an accurate account of the weights you actually supply. If you have to supply more than you estimated you may not have calculated the windows closely—check up to see where the trouble is, and then try again—you will soon learn how to do it so your estimate will cover the requirements. To make money your requirements must be covered by the estimate.

And now sash cord or sash chain will be needed to carry the sash and weights. A good quality braided white cotton sash cord of proper size will give very good satisfaction for a long time. Try not to use a poor quality. It comes in sizes 7, 8, 9 and 10, denoting a diameter of $\frac{7}{32}$ -in., $\frac{8}{32}$ -in., $\frac{9}{32}$ -in., $\frac{10}{32}$ -in. No. 7 for light sash will do, but for good dwellings you had better use No. 8 and for heavy sash No. 9, but the cord must be of a size that will fit into

the groove of the pulley or it will cut out on the flanges of the wheel. For high-grade dwellings and public buildings a copper composition metal sash chain should be used. It is made in several sizes suitable for the different weights of sash. Some of the makers use a number to designate the size, which number also represents the weight in pounds of the sash for which they recommend that particular size.

Hardware for “metal covered” fire doors and shutters is a special line of goods made to conform to the fire and insurance regulations of different localities. In the main there are heavy wrought iron hinges and eyes for hinged doors and shutters, such as Fig. 186. There are heavy wrought iron hangers, tracks, bumpers and guides for sliding doors and shutters, as shown in Fig. 187. All parts secured to brick walls must be either built into or bolted through the wall. These doors and shutters are equipped with weights, chains, pulleys and fusible links so that they will automatically close in case of fire.

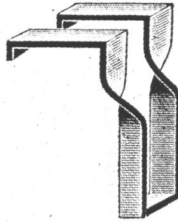


Fig. 185—Joint hanger

CHAPTER X.

Metals, Finishes and Woods

THE material of which an article is made, the manner in which the material is treated and the finish put on the material are the general standards by which we measure the value of an article. In the realm of metals all articles need not and should not be made of gold or silver, neither should all be made of iron—each metal has its proper uses and the various articles are best made of certain metals. This general idea applies as well to hardware as to other metal articles. It is the idea in this sketch to assist in the forming of a reasonable knowledge of the several metals properly used in making builders' hardware and the finishes applied to them.

The principal metals are iron, steel, brass and bronze. Many other metals are used in composition and for smaller parts, but the four above are the ones of which a good “working knowledge” will at times be found convenient.

The Value of Cast Iron

Iron is generally well enough known to require little explanation. In hardware it is usually used in the form of cast iron—sometimes known as “gray iron castings” from its color. It is not malleable or ductile and cannot be tempered. It is quite hard and to some degree brittle; that is, it may be broken by a sharp

blow or other sudden shock. Where it wears one piece against another it will stand more use than any other metal used in hardware. It is very strong in resisting steady strains and wear.

Because it is a low priced metal, and because it is easily cast into any desired shape and can be drilled and otherwise machined without difficulty, it is a very desirable metal from which to make the cases and many of the interior parts for locks, the cases and wheels for sash pulleys, butts for doors where expense is an item and where long wearing quality is important, bolts of various kinds, sash fasts for the less expensive places and many of the unexposed items of hardware.

Malleable Iron

There are places where strong hardware is required and at the same time it must have the quality to resist breaking from a blow or sudden shock; such may be made of what is known as malleable iron. This is made from an iron ore especially low in carbon and sulphur, treated and smelted by a process to eliminate as nearly as possible the small amount of carbon and sulphur as it is converted into "pigs"; these are melted in a coke furnace and cast into the desired shapes much the same as "gray iron castings." After it is cast it is heated in a special furnace to 1450 deg. to 1600 deg. and then allowed to cool very slowly. This process softens the castings somewhat and removes the brittleness, but gives much added strength to resist sharp blows or sudden shocks without breaking. It will also, to a limited extent, bend before it will break. Malleable iron is sometimes referred to as semi-steel, but, of course, must not be confused with "cast steel" which is used in making certain tools.

Steel and Its Uses

Steel is iron which has been refined to a point where it is ductile, and may be rolled into sheets or rods and drawn into wire. The sheets are passed between rolls while cold, which gives them a very smooth surface; this is known as "cold rolled steel," and it is this grade of steel that is shaped by dies into a large variety of hardware items, such as knobs, escutcheons, butts, bolts, sash lifts and a great variety of other goods. This steel must be much softer than cast iron or it could not be shaped as it is, and it must not be confused with tool steel, which may be tempered until it will hold a cutting edge.

Cast iron, malleable iron, and steel have at least one common disadvantage in hardware—they will not resist rust, and there is no known process that will eliminate this disadvantage. There are certain treatments to which they may be subjected which reduce to an extent this tendency to rust, but because of the chemical impurities of these metals the rust will, under many conditions, find its way through and mar the surface. To insure against this very undesirable condition some metal that will not rust must be used, and the ones most used in hardware are "brass" and "bronze."

Brass and Bronze

"Brass" is a lemon colored composition of copper, spelter (which is the foundry name for zinc), tin and lead. The proportions are about two-thirds copper and one-third spelter, the tin and lead constituting a very small percentage. In some trades brass is known as "yellow bronze."

"Bronze" is an orange colored composition of copper, spelter, tin and lead, but the proportions are different. For high-grade work a common proportion is approximately 85 per cent copper and 10 per cent spelter, with the remaining 5 per cent divided between tin and lead. The color may be varied by a slight change in the proportion of copper and spelter. The more copper used the more red is the metal, but it is not so hard. "Bronze" is sometimes called "red bronze," to differentiate it from the "yellow bronze" or brass.

"Nickeline" or "White Bronze"

There is another composition metal that is composed of a much smaller proportion of copper than is bronze, usually about 60 per cent copper with the remaining 40 per cent divided between nickel, spelter, lead and tin. The proportions vary somewhat according to the uses to be made of the metal. The nickel and spelter produce the white color, but at the same time make the composition harder and more difficult to machine than either brass or bronze. For this reason and because of the higher price of the nickel over copper, goods made of it cost considerably more than if made of brass and bronze. This metal has and will retain indefinitely the appearance of fine nickel-plated goods. It is particularly suitable for hardware used in toilets and bathrooms.

This metal is sometimes called "nickeline," "white bronze" or "eclipse metal."

Both brass and bronze may be cast, rolled into sheets and drawn into wire. The sheets may be shaped into knobs, escutcheons, sash lifts and other pieces of hardware by means of dies. When price should be considered they serve well, but the higher grades of hardware are made of cast brass or bronze.

Various Kinds of Finishes

After the metals are cast or formed into the desired pieces of hardware they must be finished, both as a protection and in order to improve their appearance. The first step toward this is the preparation of the surface to receive the finish. For certain finishes on cast iron, malleable iron and steel goods which are intended only for utility without the necessity of considering appearance, the surface of the article as it comes from the foundry or press room is quite satisfactory. All brass or bronze goods and iron and steel goods that are to be finished to imitate real brass or bronze must have the surface prepared in a way suited to the finish to be applied. The surfaces, sometimes referred to as the "texture" of the surface, may be arranged into three groups—polished or bright, satin or scoured and sanded or matted.

"Polished" and "Satin" Surfaces

The polished surface is produced by grinding and polishing on an emery wheel or by putting a number of pieces together with a quantity of steel balls in a rolling barrel and tumbling them until the surface is smooth. The second method is sometimes called "rolled" or "friction" polished. The method of polishing depends largely upon the shape of the article and the smoothness of surface required. The "satin" surface is usually produced by scouring an already smooth surface with very fine sand and emery. Generally this surface is put on as one of the final finishing operations.

"Sanded" or "Matted" Surfaces

The "sanded" or "matted" surfaces are produced in entirely different ways, but the final effect is largely the same. When the surfaces are mostly plain and are not very ornamental the article is put under a blast of either fine or coarse sand, according to the texture of surface desired. When portions of the ornamentation are raised to one plane these are sometimes ground off smooth and finished either bright or satin finish in order to lend a contrast and bring out the design. In some cases, especially in cast goods, the depressed surfaces are given a somewhat sanded effect by having that portion of the pattern "matted"; that is, tooled to form a roughened surface, and this is reproduced in the finished casting. This same effect may be produced in wrought metal by having the die "matted" where desired and pressed into the metal as the article is formed on the powerful presses.

After the surface has been prepared as desired the articles must be thoroughly cleaned by various cleansing agencies suited to each particular condition. This may, in a general way, be classed as "washing." They are then ready for the final finish. If the natural bright color of the metal is desired the article is buffed, again "washed" to remove any possible dirt and lacquered. It is then ready for use. Here is as good a place as any to say that all brass, bronze or plated steel hardware is lacquered; that is, covered with a special kind of varnish to protect the metal from tarnish. It should not be understood, however, that the lacquer will give any prolonged protection to such parts of hardware that are handled and receive much wear, such as door knobs. When the lacquer wears off or is removed in any way the metal will naturally tarnish. If spots of paint are found on the hardware the turpentine of the paint or alcohol used in removing them will also remove the lacquer and the metal will tarnish in such spots, sometimes before the building is occupied. Usually bright nickel is not lacquered, as this metal has a natural strong resistance to tarnish.

Iron or steel hardware, when it is desired to imitate the appearance of brass or bronze, must be plated, and when certain color effects are desired on brass or bronze they too must be plated. After the cleansing or washing process the articles are suspended in a plating solution containing the metal desired. With the aid of electricity this metal is gradually transferred to and deposited on the article to be plated. The thickness of the plating depends largely on the length of time consumed.

The many colors of hardware finishes are obtained by using the natural color of the metals themselves, or by changing the proportions of the component parts of the composition metals, such as brass or bronze, or by plating, oxidation, or other treatment of the surfaces.

The colors of the natural, or of the composition metals, are uniform throughout any one piece of metal. From this it will be seen that these colors are permanent save that they will darken slightly, in time, by tarnishing—which is nature's oxidation. As this tarnish mellows it gives a very beautiful color effect. However, if this is not the effect desired these metals

may be kept in their original bright colors indefinitely by the use of a good metal polish. These colors are the bright lemon color of brass, the coppery orange of bronze, the white of nickeline, and their modifications produced by scouring, sanding and matting.

The colors produced by plating or by oxidation are surface colors and do not extend through the entire piece, consequently they have not the degree of permanency as the natural colors, but for all that they are very useful in color combinations and usually give very good satisfaction.

Classification of Finishes

Recently the principal hardware manufacturers working with the Bureau of Standards of the Department of Commerce, Washington, D. C., reviewed the subject of "Finishes" as applied to hardware and worked out the following classification which seems to be a sufficiently large assortment to meet any reasonable requirement and it is quite desirable to confine the demand for finishes within these limits.

Each finish was assigned a Government number preceded by the letters "U. S." Each manufacturer has, however, his own designating symbols (letters, numbers, or a combination of letters and numbers) to designate the different finishes. The government numbers only are used here.

U. S. 1—"Japanned." This is a quickly drying black lacquer or varnish applied to iron and steel goods, and while this covering remains perfect it affords a good protection from rust.

The "Hot Galvanized" Finish

U. S. 2—"Hot Galvanized, Electro-Galvanized, or Sherardized." These finishes are applied to iron or steel to make them rust resisting. The idea is to cover the iron or steel with a coating of zinc. Each of the three names mentioned represents a different method of accomplishing it. For either method it is important to have the articles to be zinc coated thoroughly cleaned. This may be done by sand blasting—tumbling in a rolling barrel, or by scouring.

In the "hot-galvanizing" process the article, after cleaning, is first dipped into muriatic acid and then into a bath of molten zinc, heated to about 800 deg. Here it is allowed to remain until it becomes about the same heat as the zinc. When it is removed it is thoroughly coated with the zinc and when it cools it is dipped into water in order to bring out the bright zinc color. This is considered, by many, to be the most thorough method of zinc coating and to give the most lasting satisfaction.

Electro-Galvanizing

In "electro-galvanizing" the article is placed in a plating solution with zinc which is deposited on the article with the aid of electricity. This is a particularly satisfactory method for small working parts or where a very smooth surface is required, but it is likely to be less rust-resisting than is "hot-galvanizing" process.

The Sherardizing Process

"Sherardizing," deriving its name from its inventor—a Frenchman named Sherard, is produced by rolling the articles to be coated with an amount of powdered zinc in a slow revolving container heated to from 500 deg. to 600 deg. If the articles are of simple shapes the result is quite satisfactory, but there is always a chance that all recessed corners and uneven surfaces

may not be thoroughly coated, and consequently many do not consider it equal in resisting rust to the "hot-galvanizing" process.

Brass Finishes

U. S. 3—"Plain or natural brass." This is the natural "brass" usually buffed bright.

U. S. 4—"Dull brass"—sometimes known as "old brass," "lemon brass" or "scoured brass." This is the natural brass scoured with fine pumice stone and sand to produce a satin surface.

U. S. 5—"Dull brass—oxidized and relieved." This is intended for ornamental surfaces. The oxidation darkens the depressed surfaces while the raised portions are relieved to match No. 4.

U. S. 6—"Sanded brass—oxidized and relieved." This is the same as No. 5 except the surface is sanded instead of scoured.

U. S. 7—"Sanded brass—oxidized and relieved with the raised ornamentation polished." This is similar to No. 6 save that the raised portions of ornamented goods, or the edges of plain goods are polished and buffed to bright brass.

U. S. 8—"Antique copper." This is a copper finish oxidized to a very dark brown or even black and then relieved in places so that the varying copper shades show through. This has been a very satisfactory and popular finish for years, but its popularity has been its downfall, as many people now want a change.

Bronze Finishes

U. S. 9—"Plain or natural bronze." This is the natural "bronze" usually buffed bright.

U. S. 10—"Dull bronze." The natural bronze scoured to produce a satin surface.

U. S. 11—"Dull bronze—oxidized and relieved." Intended for ornamental surfaces, the oxidation darkens the depressed surfaces while the raised portions are relieved to match No. 10.

U. S. 12—"Sanded bronze—oxidized and relieved." Same as No. 11 save that the surface is sanded instead of scoured.

U. S. 13—"Sanded bronze—oxidized and relieved, raised ornamentation polished." This the same as No. 7 except that it is on bronze instead of on brass.

Nickel Finishes

U. S. 14—"Nickel plated." This is bright nickel plated on either brass, bronze, steel or iron.

U. S. 15—"Nickel plated—dull." It is the same as No. 14, with a satin surface instead of bright surface.

U. S. 16—"Nickel plated—oxidized and relieved." This has the sanded surface darkened by oxidation but lightened on the high parts.

U. S. 17—"Nickel plated—oxidized and relieved, raised ornamentation polished." This differs from No. 16 only in that the high parts are polished and buffed bright, as in No. 7 and No. 13.

U. S. 18—"Rust-proof—black—Bower-Barff". This is a finish for iron or steel only. It is produced by heat in a special furnace and gives the surface, which is usually sanded, a coating of carbon. It is then further treated in order to give it a dead black color.

This finish is generally referred to as "rustproof," but because of imperfections which are not easily avoidable it should not be recommended for damp places. With this exception it wears particularly well.

This finish is very commonly referred to as "Bower-Barff," which name is derived from the names of the men who invented this finish. As the name is copyrighted, only certain people have the right to use it, but the same general effect is produced and sold under other names, which do not necessarily indicate a less desirable result.

U. S. 19—"Sanded, dull black." This is a finish in imitation of No. 17—produced by copper plating and oxidation, it may be put on brass, bronze, iron or steel. It has no special, rust-resisting quality, and does not wear as well as No. 18.

U. S. 20—"Statuary bronze." This is a copper finish on bronze of an even color, somewhat similar to that of statuary; it can be made in different shades, from rather light brown to quite dark.

U. S. 21—"Statuary bronze—sanded." This is the same as No. 20, but the surface is sanded instead of polished.

U. S. 22—"Verde antique." This is a finish on bronze to give the effect of old metal, with the green of the verdigris showing more or less. It is sometimes made with most of the article in "statuary bronze," with only a small amount of the green showing in the recessed places. While again it may be made with the green largely predominating. It is not especially desirable that all pieces of a kind appear alike, since nature would not do it that way.

Silver and Gold Plating

U. S. 23—"Silver plated—dull." This is silver plated on brass or bronze and scoured to give a satin surface.

U. S. 24—"Gold plated—dull." Gold plated on brass or bronze, with a satin surface. There are so many shades possible in gold plating that it is usually done to meet some special color effect.

U. S. 25—"White bronze." This is a special mixture of copper, spelter and tin made to produce the effect of nickel. This was mentioned in the preceding installment.

Other Special Finishes

In addition to the above, four other finishes were classified as "special":

U. S. 16—Special—"Nickel plated, imitation half-polished iron, sanded, oxidized and relieved." This finish is made to represent the higher grades of wrought-iron work, intended for use where certain artistic effects are desired.

U. S. 21—Special—"Fine wheel finish." Brass or bronze polished on a fine emery wheel but not buffed.

U. S. 25—Special—"Dull brass or bronze, oxidized and oil rubbed." A finish slightly darker than No. 4 and No. 10, rubbed with an oil preparation instead of being lacquered. In use, it takes on a very mellow oxidation.

U. S. 26—Special—"Statuary bronze—waxed." This is similar to No. 20, but treated with a wax instead of being lacquered.

Many of the finishes described here may be put on

iron or steel and make very good imitations of the real brass or bronze. Such goods have their place where low cost should be considered, but they should not be recommended for high-class work.

Some of the color effects on electroliers are produced by means of colored lacquers, and for the purpose give very good satisfaction. Owing to the fact that hardware is subject to more or less handling, it is not practicable to attempt to exactly match all the shades of color of the lighting fixtures.

If sulphur in any form comes near brass or bronze or their finishes, it is likely to discolor it. Rubber and certain papers carry enough sulphur to do this. Most manufacturers wrap their goods in "anti-tarnish" paper.

Harmonizing with Woodwork

Consideration should be given to recommending hardware in a finish that will harmonize with the color of the woodwork.

Bright brass or dull brass look very well on white paint, and are also particularly attractive on mahogany—bright bronze or any of the dull and slightly oxidized bronze finishes are good on mahogany; in fact, mahogany harmonizes with a large range of finishes. Slightly oxidized dull silver or nickel with mahogany and blue decorations also gives a pleasing effect.

The darker and sanded brass finishes are appropriate for the dark shades of oak, as is the black iron. These are only a few suggestions to bring out the idea that there is "something to it," and that an ability to harmonize colors has its place in builders' hardware.

CHAPTER XI.

Architecture and Its Relation to Hardware

ARCHITECTURE is a record of man's development—a record of human progress. It is the practical art of building. The designing of architecture is the adapting of its elements to immediate needs. This and the search for perfection have been the strong forces which have carried the art forward. Builders' hardware should be considered as serving an architectural need both as to adaptability and to ornamentation. Architecture by no means deals only with the decorations and ornamental features of buildings. The gaudy "movie-picture palace" may drip with alleged ornamentation but still have no speaking acquaintance with real architecture, while a simple, well proportioned building may be an architectural masterpiece.

An architect may reasonably doubt that a builders' hardware salesman is a competent judge of his work, yet he doubtless would be pleased to know that the salesman has some intelligent recognition of the outstanding features of the creation of his brain, and so a passing acquaintance with the more common architectural features is necessary to enable one to intelligently suggest proper hardware.

Periods of Architecture

Since architecture is a record of the development of civilization, and since its course has not been an even one, but has been subject to advancement and retrogression as the centuries passed it naturally divides itself into periods of time, each having its own outstanding features. For purposes of classification the architecture of these periods of time are referred to as "periods of architecture" or "schools of design." These periods are usually known by some prominent name of the period rather than by the years. For example, in French architecture we have the "Louis XVI" period, meaning during the reign of Louis XVI.

Many of the decorative features of the architecture of these periods have been reproduced in the hardware designed for use with them, therefore it will be the endeavor here to point out some of the salient features of the more important of the periods.

For the purpose of this article it is not necessary to

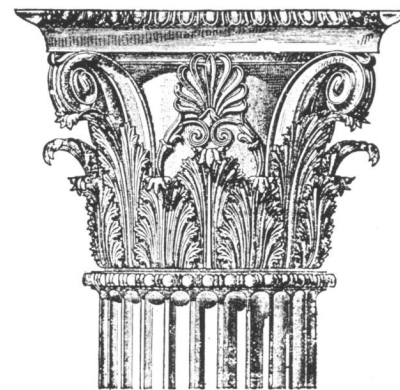


Fig. 190
Corinthian capital

attempt to outline the early beginnings such as the architecture of India, Egypt, Babylonia, Assyria, Persia, and China, but to content ourselves with considering the periods which laid the foundation upon which our modern architecture has grown. The first of these is the Greek, which had its beginning some 1200 years B. C. and continued until about the middle of the second century A. D. It is said to have reached its highest perfection during the "Golden Age of Pericles" about 440 B. C.

The "Greek," together with the later developed "Roman period," is frequently referred to as the "classic architecture." In a general way it is the main root from which the present-day architecture grew. The Greek ideals of moderation, proportion, and beauty are all outstanding characteristics. "How far to go" seems to have been an intuition with them. Their public and private contributions of money and time to their enthusiasm for, and love of, the beautiful resulted in the high perfection of their art.

The Three Greek Orders

Greek architecture may be divided into three classes or orders, Doric, Ionic and Corinthian, and it is in the columns that the difference of style is most easily perceptible.

The Doric column (Fig. 188), the first in sequence, has a very simple top or capital and was, at the begin-

ning, low and quite heavy, but developed to lighter and more graceful proportions until it reached its perfection in the Parthenon, which was built some 440 years B. C. and is considered the best model of the Doric order. The cornice moldings of this order are, if at all, very simply ornamented, usually only with one of the simple Greek meander or fret borders.

The Ionic column (Fig. 189), the second in sequence, is taller and considerably lighter than the Doric. It rests on a base and has as its particular distinguishing feature a voluted head or capital. This order has more moldings, with richer and more elegant ornamentation, such as the egg-and-dart and the tongue-and-dart.

The Corinthian column (Fig. 190), the third in sequence of development, is still lighter or more slender than the Ionic. The essential difference between these two being the capital. The Corinthian is more ornamental, being decorated with acanthus leaves and buds together with four small volutes.

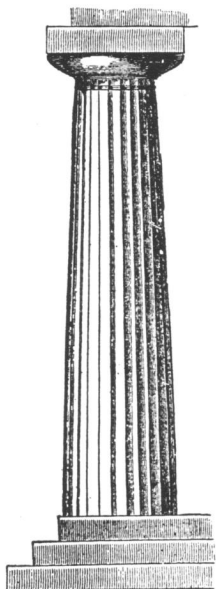
All three of these Greek column orders are at times used in the development of a single building and the types of decorations when used are more or less interchangeable.

It may be noted that all opening in the walls have straight tops, (not arched).

Buildings in the Greek style have a particularly solid rectangular appearance. Many of our public buildings, such as post-offices, banks and libraries, have been built in the "Greek period."

Roman Architecture

The Romans developed a style of architecture largely from elements borrowed from others. They were not lovers of simple beauty as were the Greeks, but rather aspired to grandeur and magnificence. From the Tuscans, who preceded them in Italy, they learned the art of building the arch. This later led to the vaulting which enabled them to build larger and more spacious buildings. From the Greeks they borrowed the three columns and much of the Greek ornamentation. The Romans were able to combine the arch and the columns with remarkable effect. Their desire for splendor constantly urged them toward more and more elaborate decorations. Many of the Greek forms of ornamentations were retained but were elaborately decorated in detail. The arch is an outstanding feature in the



Right
Fig. 189
Ionic column



Left
Fig. 188
Doric column

Roman period, and associated with the columns is very prominent in all the Roman buildings and triumphal arches.

The Byzantine Period

With the division of the Roman Empire about the end of the fourth century A. D. and the development of the Byzantine Empire with its capital at Constantinople, which had been renamed by Emperor Constantine from Byzantium, there developed a style of architecture which was a real link between the Roman and Middle Ages. The "Byzantine period" contains the love of color of the Orient, the ideals of the Greeks and the ability of composition of the Romans. They did not so much copy but rather utilized these various elements in the development of a style to meet their own requirements. They took up the vaulting and dome construction of the Romans and carried it forward until it made possible much of the architecture of later years.



Fig. 191
Byzantine capital

The columns, because of the vaulting, were not so much used for supports but rather in a subordinate way, and consequently the capitals were not so beautifully carved. They became rather bowl shaped and their ornamentations were carvings of a network of palms and other foliage or interlacing bands as of a basket, as shown in Fig. 191.

The Byzantine style is said to have reached its highest example and splendor in the church of Saint Sophia at Constantinople.

The essential feature of the Byzantine period is the dome or domes. Its influence spread over many countries, the Crusaders carried it to Western Europe and it was communicated to the Eastern countries through the routes of trade. The architecture of Russia and India shows its effect to the present day. The Taj Mahal, built in India some 300 years ago, and considered one of the architectural gems of the world, shows the Byzantine dome influence.

The Romanesque Style

The superstition of the Early Christians that the world would come to an end in the year 1000 A. D. had a paralyzing effect upon all human activities. Even though this proved a fallacy its effect lingered for many years and it was not until toward the end of the eleventh century that full recovery was evident.

The French people, affected by the architecture of the early Christian Romans and the Byzantine influence of the returning Crusaders, developed, during this period, a style of architecture known as "Romanesque." This spread from southern to northern France, thence to England with the Normans.

Its best expression is found in the churches and cathedrals of the time. Its chiefest characteristic is massiveness. It displays its greatest beauty in construction rather than in applied ornamentation. The columns and arches of the Romans and the Byzantine

vaulting prevails. The heavy arched, recessed, entrance ways are prominent. In some sections these are particularly conspicuous by reason of the sculptured saints and other religious subjects, while in other sections the ornamentation took the form of symmetrical, alternating, border patterns producing the light and shadow effect.

The Gothic Influence

During the twelfth century there arose a style of architecture which was quite free from all previously established styles. It is known as the "Gothic period" or "pointed arch style." It is said to have originated in France and spread from there to England, Germany and other countries.

The demand for churches more than twice the size of any formerly built made the roofing problem a new one and it was to meet this problem that the pointed arch principle was worked out and the necessity for the heavy walls required to withstand the thrust of the dome construction of the Roman and Byzantine periods was eliminated. Heavy piers were built at intervals to carry the pointed arch framework and the intervening spaces were filled in with tall windows and lighter construction—so the pointed arch is the outstanding feature of the Gothic period. Originally all door and window openings had the pointed arch top, but this was later varied in England when only the more prominent ones had the pointed top and then it became much lower or flatter. This period of "English Gothic" is known as "Tudor Gothic." In addition to the flattening of the arches over doors and windows they were often capped over with hood moldings which gave them a square appearance rather than pointed. The towers and walls terminated in battlements and there was less of the floral decoration used than in the Gothic of earlier dates.

The ornamentation of the Gothic is entirely free from the classic, being either geometric designs as in the large round rose window, in the ends of churches or flowers and leaves native to the country carved in the stone, also carvings of any noted church figures and quaint images as well as grotesque animal heads as gutter spouts or gargoyles. The cathedrals of Amiens, Rheims and Notre Dame in France, and of York and Canterbury in England, are prominent examples of the development of the Gothic in these countries. In this country many churches, educational buildings, and later a number of large office buildings are of the "Gothic period."

The Period of the Renaissance

The "Renaissance period" in architecture was the bringing back of the old Greek and Roman forms which had laid rather dormant for a thousand years or so. The overthrow of the Byzantine Empire in the fifteenth century caused many of the artists, architects and scholars of that country to seek new homes. Many of them went to Italy and France, carrying with them their traditions. In architecture these found acceptance and were readily intermingled with the styles then being used.

Italy had by then rather run her course so far as the Romanesque and Gothic was concerned, and eagerly

adopted the chaste classic ornamentations as these had a strong appeal to their temperament. This was rather a rebuilding of the architecture of the different countries as the wave progressed but not the same in all countries, thus there was the Renaissance of Italy, France, Germany, Spain and England, so the outstanding features of the "Renaissance" or "transition" period of the different countries are not as prominent as in some of the more original periods.

Elizabethan Architecture

The "Elizabethan period" of architecture was developed during the Renaissance in England and the reign of Queen Elizabeth. It found its best expression in the country mansions of the nobility of that time. Some of the characteristics of this period are the curved broken gables, pilasters broken by bands and the grouping of many small windows in one large opening. The ornaments are cumbrous, rich and gorgeous, rather than graceful and comfortable. This style is frequently used in American country houses.

About this time the Flemish style was developing in the Dutch countries. The decoration of the belts and bands, the geometric spots with facets inserted in the bands, and the curly edged panels all very closely resemble those of the Elizabethan.

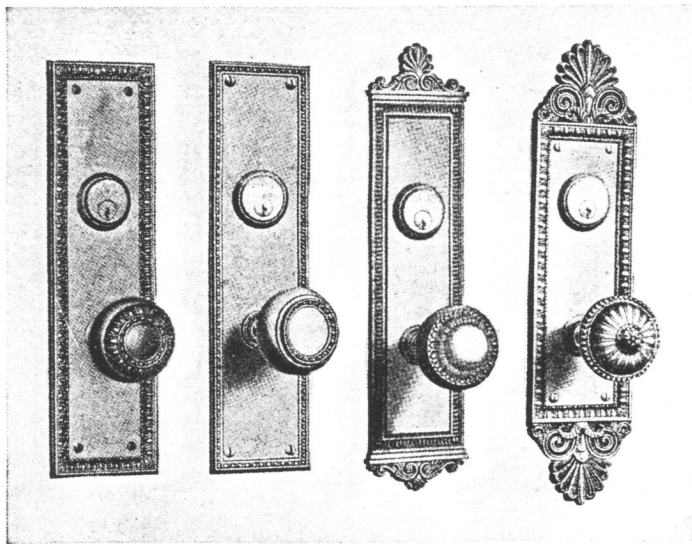
Later French Styles

The architecture of the reign of Louis XIV is the beginning of the French periods known best in the present day. Influenced by the classic it is particularly symmetrical and well balanced in every detail. In the decorations there is much reserve, the moldings that formed the wall paneling were strong and ornamented at the corners by scrolls. Wreaths and medallions are frequently employed, all giving an air of well restrained pomp and display.

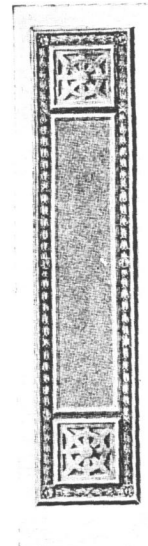
During the reign of Louis XV the ornamentation became much more lavish in scrolls, flowers and shells. While a regard for proportion was retained the straight lines of restraint which were prominent in the Louis XIV gave way to a twisting and curving of the moldings. All giving the impression of extremely over-rich luxuriance. This period is also known as the "Rococo."

The general refinement of the reign of Louis XVI is reflected in the architectural decorations of that period. This reaction brought back and developed the restraint of the period of Louis XIV. The ornamentations were refined and used more sparingly, the whole giving the feeling of aristocratic refinement.

With the crowning of Napoleon I as Emperor of France, there arose a new aristocracy and nobility from those who had acquired success and riches through the favor of Napoleon. These sought to outdo the elegance of the preceding royalty, and there grew up what is known as the "Empire" style which was supremely rich, though cold and formal. The decorations and ornamentation were of the Roman forms. Much mahogany was used, with wreaths, torches and festoons of gold and brass set on, all symbolizing the ambition of Napoleon to surpass the grandeur of the Roman emperors.



At left—Fig. 192
Divisions A, B,
C and D left to
right showing
Greek designs



Left—Fig. 193—
A Roman design

Right—Fig. 194
— Romanesque
decoration



CHAPTER XII.

Hardware Suited to Period Architecture

BUILDINGS of today conforming in design to any of the periods of architecture must at the same time conform in both shape and arrangement to modern uses and conveniences. This same treatment is applied to the hardware for such buildings. In size, shape and mechanical construction it must embody all the very latest ideas, but in ornamentation it should be true to the period of architecture of the building on which it is used. In order to illustrate how this is worked out and to give an idea of the style of hardware suited to certain architectural periods, a number

of cuts of knobs and escutcheons have been selected from the many designs manufactured by several of the largest makers of builders' hardware. Other makers, no doubt, have designs of equal merit, but limited space makes it necessary to be content with those shown here.

Fig. 192 shows several very good Greek designs. In divisions A and B will be noted the plain square Greek Doric effect. In A the "egg and dart" and "pearl and bead" borders are used for simple ornamentation, while in B there only the "pearl and bead" border is

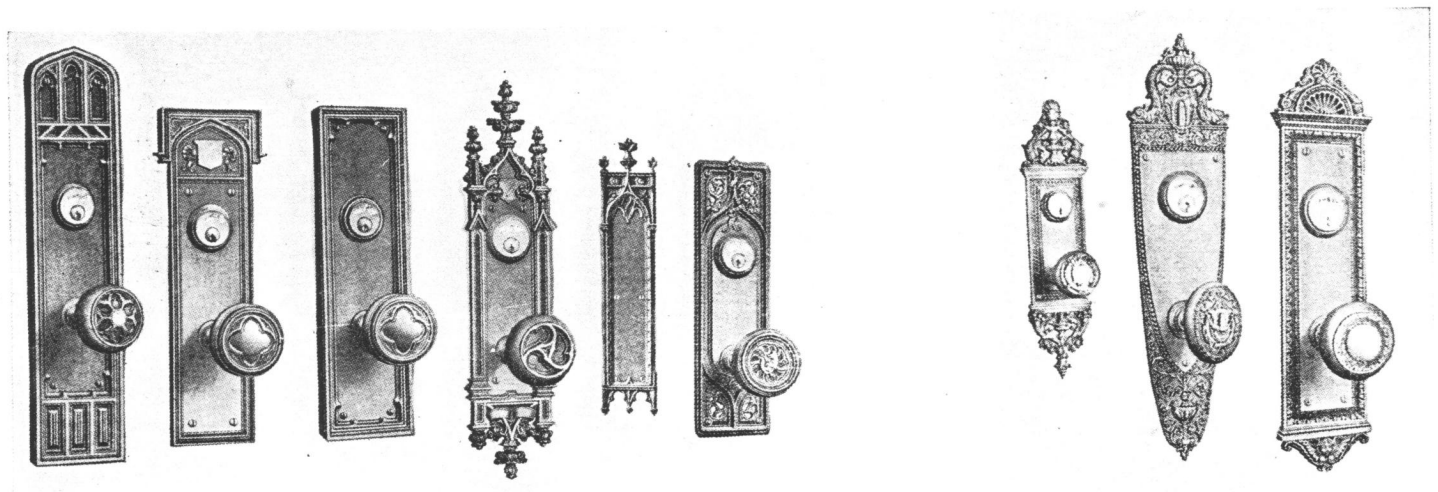
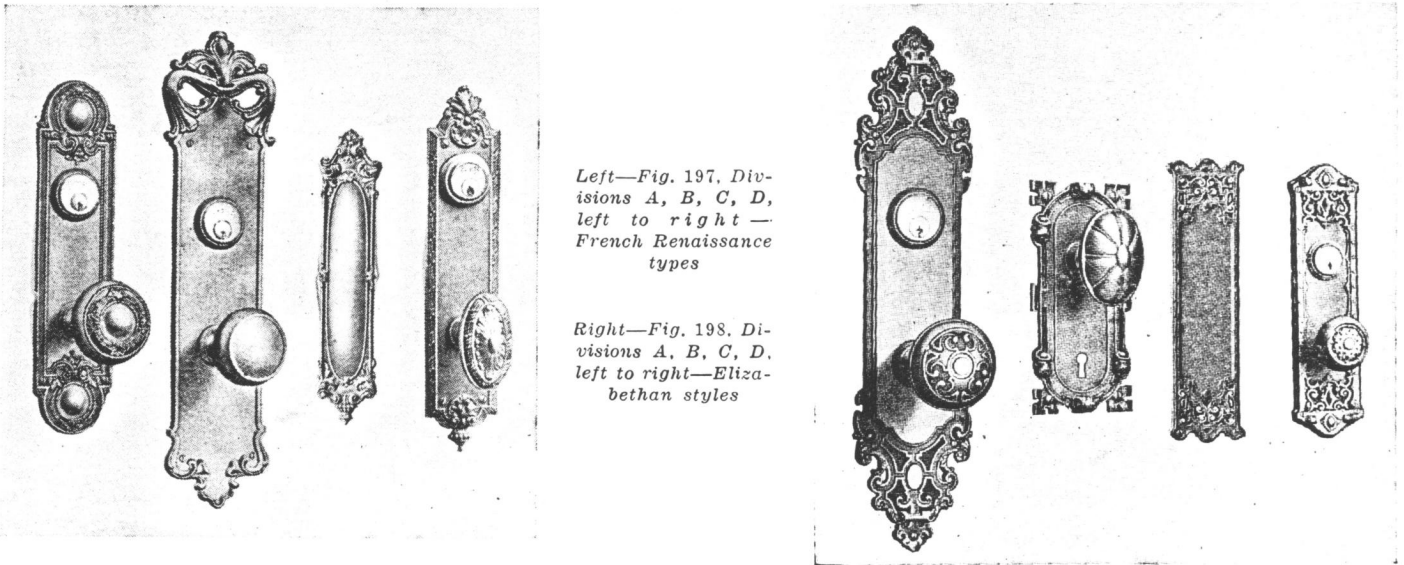


Fig. 195—Divisions A, B, C, D, E and F left to right showing the Gothic influence

Fig. 196—Divisions A, B, and C Italian Renaissance types



Left—Fig. 197, Divisions A, B, C, D, left to right—French Renaissance types

Right—Fig. 198, Divisions A, B, C, D, left to right—Elizabethan styles

used. In *C* the ornamentation is a little more elaborate, making it better suited to the Ionic order, as this order is usually slightly more decorative than the Doric. In *D* there is associated with the “egg and dart” and “pearl and bead” the “palm” and “acanthus” leaves, suiting it to use with architecture of the “Corinthian” style.

Fig. 193 is a design well adapted for use on buildings of the Roman period. The border of buds and beads and the lattice work at the ends are frequently employed.

As has been previously shown, the Roman architectural decorations were largely drawn from the Greek and for this reason hardware with Greek decoration is frequently quite appropriate for use on buildings of Roman design.

The Byzantine architecture is more prominent in its structural rather than in its decorative features, the Roman ornamentation was largely employed. Since this period of architecture is not much used in our

time, there are few examples of hardware designed especially for it. Often the Greek and Roman designs are quite well adapted to the ornamentation used.

In Fig. 194 is shown a piece of hardware with the leaf decorations so frequently worked into styles of the Romanesque period. As there are comparatively few buildings designed today in this period of architecture there is naturally not a very large assortment of hardware designs in this school, but this one will serve to show the general character.

The variety of Gothic designs is quite large because this period of architecture is employed at times in the whole range of buildings—churches, homes, schools, colleges, skyscraping office buildings and almost every kind of public buildings. Fig. 195 shows a number of representative examples. *A, B* and *C* are particularly suited for buildings of the English or Tudor type. *A* and *B* use the low arch while *B* also has the cap. All three are rather plain and without the leaf decorations used so much in other styles of Gothic.

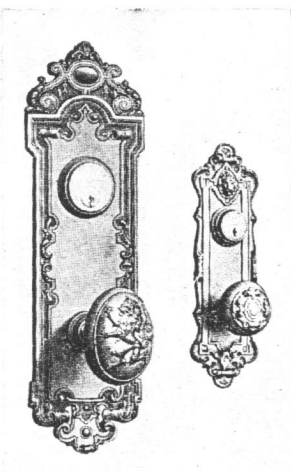


Fig. 199—Two Flemish designs

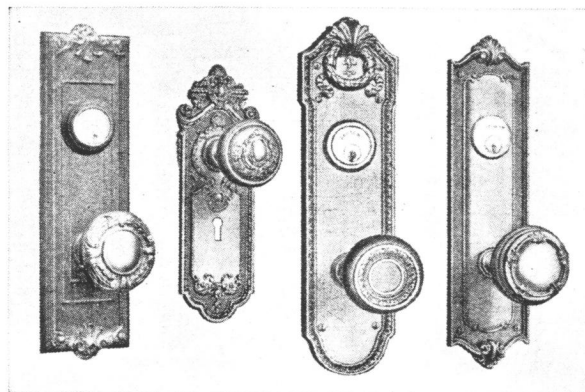


Fig. 200—Divisions A, B, C, D, left to right—Louis XIV hardware

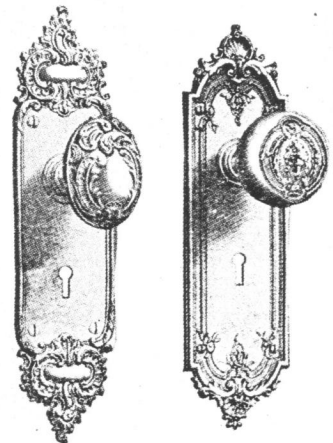


Fig. 201—Louis XV hardware

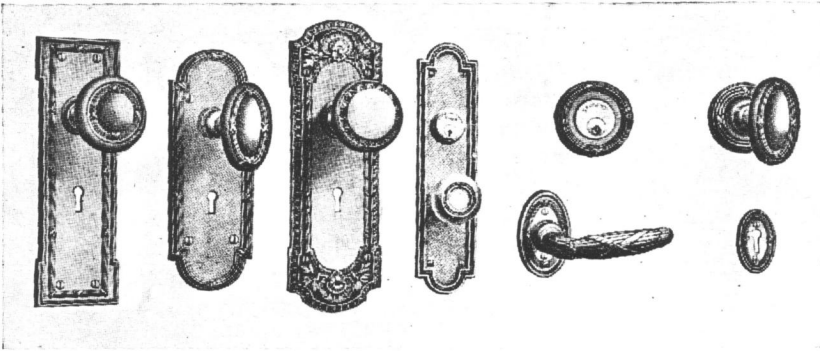


Fig. 202—Divisions A, B, C, D, E and F, left to right—Some excellent examples of hardware suitable for use in connection with architecture of the Louis XVI period

The double curve of the arch shown in *D* and *E* was used in the Gothic of the Fifteenth Century. These are quite "churchy," and by some are referred to as "Ecclesiastical Gothic," meaning that they are particularly suited for churches. *F* is a design showing the delicate French treatment with the perforated tracery in the corners.

Renaissance Hardware

During the Italian Renaissance there was a great deal of ornamentation associated with the classic borders, as is seen in the examples shown in Fig. 196. In *A* and *C* the orderly panels of the Greek and Roman period form the foundations to receive the more elaborate ornamentation of the Italian temperament.

The French Renaissance is usually more reserved than the Italian, as will be noted in the pieces shown in Fig. 197, and the ornamentation shows the leaf and floral carvings of the Gothic period, which preceded it. The orderly arrangement shows the trend toward the well-balanced decorations of the Louis XIV period.

Elizabethan hardware is particularly designed for homes rather than for public buildings, as that is where this period of architecture is most employed. In Fig. 198 are shown several examples by different makers. The curling edges to the scrolls is a characteristic feature, with protruding facets, like nail heads, showing in the fretwork of the designs at *C* and *D*. The ends of the panel of *A* resembles the curved, broken gables of the houses of this period.

Fig. 199 shows two Flemish designs. The similarity of these to the Elizabethan will at once be observed; in fact, they may be interchanged without committing a very grave error. Note that the lion is prominent in both these designs. On the knob of *A* the "rampant lion" is used as it was on the coat of arms of the Duke of Flanders.

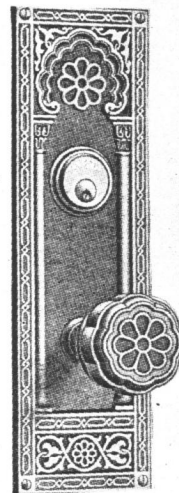
Several Louis XIV designs are shown in Fig. 200. The panels with molded edges, and the leaf and scroll decorations are characteristic—*B* and *C* show the classic borders. The frequently used wreath is employed in *C*, while the balance and symmetry so prominent in the Louis XIV ornamentation treatment will be noted in all four.

Hardware of the Louis XV period is not frequently required, as this style of decoration is not much used—a room or two in an elaborate dwelling or hotel, but seldom more. The lavish ornamentation of this time does not work out particularly well in hardware. In Fig. 201 are shown two designs, *A* shows the lack of restraint peculiar to this period, while in *B* the shells,

flowers and wreaths are employed, but with more regard for order.

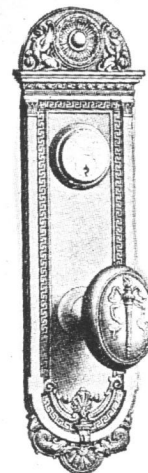
The refinement of the Louis XVI period is very noticeable in the examples of hardware shown in Fig. 202, and well-balanced simplicity predominates. In *E* and *F* are shown "sectional trim" treatment, which is quite appropriate to the dignity of this style.

Two very good designs suited to Moorish architecture, which developed in southern Spain from the ninth century until the Moors were driven out by Ferdinand and Isabella in 1492, are shown in Fig. 203. The Moors left as an example of their architecture the king's palace, the Alhambra at Granada. Note the tracery of geometric patterns of interlacing lines and in *A* the cusped horseshoe arch.



Left — Fig. 203 — Two Moorish designs

Right — Fig. 201 — Hardware of the Empire period



Hardware of the Empire period is shown in Fig. 204. In A is shown the adaptation of several of the Greek and Roman symbols. The meander border, commonly called the "walls of Troy," the "griffins" at the top representing the guarding of their gold, the "dolphins" at the bottom signifying the heir to the throne of France, and the upright "torch" on the knob being the symbol of joy and unrestraint. B shows the torch that appears in A and the Roman wreath of the victor. All of these are symbolical of the desire for pomp and grandeur of the Empire period.

In connection with the large range of ornamental designs in hardware conforming in decoration with the

various architectural periods, it is well not to overlook what is well described as plain designs, that is, knobs and escutcheons without any ornamentation.

The simple plainness of these is their principal charm, and has a very strong appeal for many people. A smaller mistake will be made if plain hardware be used than if a poorly selected ornamental design be used, especially if there is not too much display made of the hardware. Care should be used to select sizes of escutcheons and other pieces, and of finishes, so it will all harmonize with its surroundings and look as though it were there for use rather than show.

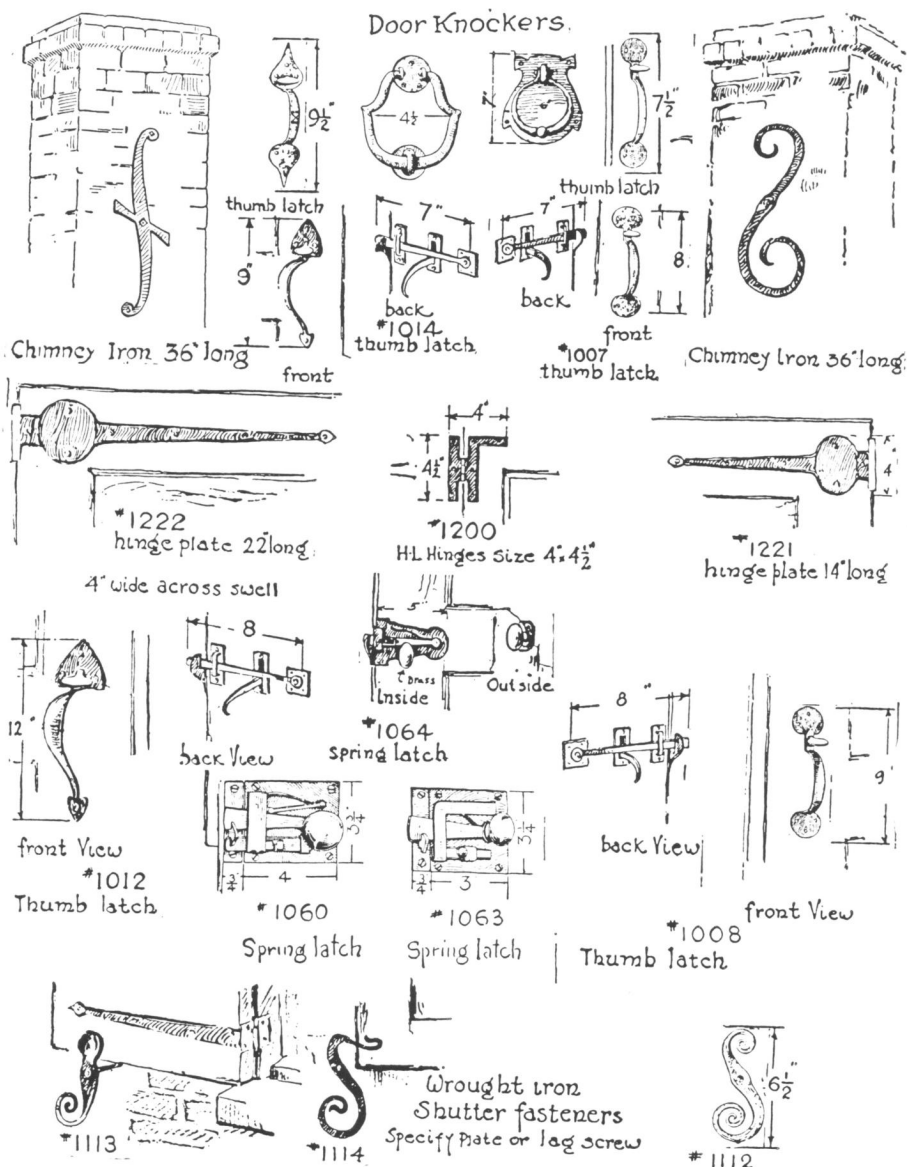
CHAPTER XIII.

Colonial Hardware and Architecture

IN the years between 1700 and 1800 the builders in this country laid the foundation for a style of architecture that has been more generally adopted

as meeting the needs of our tastes and manner of living than does any other. The styles of that period and their developments in the years that have followed are known as "Colonial."

In those early years the styles of the several centers of colonization were influenced largely by the styles of the mother country from whence the builders came, at the same time being adapted by necessity and local environment to the requirements of their lives in their new homes, the French in the north along the St. Lawrence and in Louisiana to the south; the Puritans in New England; the Dutch, followed by the English, around New York; the Quakers in Pennsylvania; the Swedes in Delaware and Maryland; the English gentry in Virginia; and in a smaller way the Spanish in certain sections of the South. Each of these groups of people left their imprint upon the buildings that survived them, but it is to the English that we are largely indebted for the motifs that have been developed into our modern Colonial architecture.



At the left is shown some typical designs in "Old Colonial" builders' hardware, taken from the catalog of James Peters & Sons. Hardware of this type is usually made of hand wrought iron, painted black. Bright brass knobs and small parts add to the attractiveness of this style of hardware

There are two general types of Colonial that may reasonably be classed as "Northern Colonial" and "Southern Colonial." These are the natural results of the heredity and environment of the two distinct classes of English people who produced them. The religious intolerance of the English rulers drove to New England a body of sturdy people known as Puritans. These people, moved by a desire to worship according to their own ideals, came as permanent settlers and were well fitted to combat the obstacles that lay in their paths to new lives and new homes. They were home builders. By religion and by necessity they were a working people of simple tastes and their daily activities centered around the hearthstone. The climate forced them to build compactly in order to make it possible to keep warm in winter.

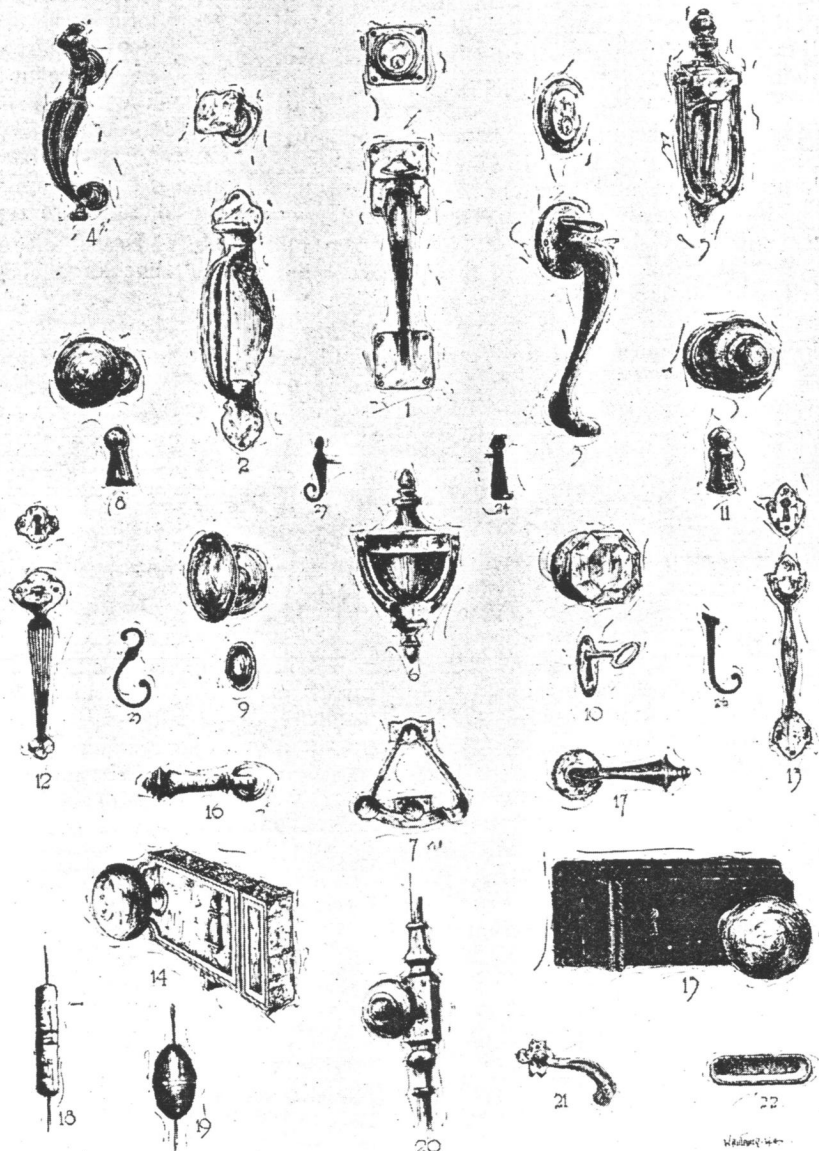
The iron rule of Cromwell made life for the English gentry anything but agreeable and it was to America that they came, settling principally in Virginia. They were natural aristocrats of means and were accustomed to English country life. The productive soil, the pleasant climate and slave labor lent themselves admirably to their mode of living. Their homes were designed less compactly than those of the North and with a view toward entertainment and hospitality.

The various styles of these several localities became gradually merged into one general style which since about 1800 has been designated as "Colonial." It is, thus, the adaptation and interpretation of the different styles of the mother country, perhaps more than originality, that makes the "Colonial" a style of its own.

Proportion and simplicity are prominent characteristics. The generous entrance hall, the square rooms with low ceilings and the wide doors and windows all produce the effect of informality and cordiality. A circular headed window, flanked on either side by a narrow window, the top of which is on the line of the spring of the arch of the central circular one, appears in almost every build-

ing. This style of window is sometimes called a palladian window. Where columns and pilasters are used, as at entrance porches, the Ionic capitals usually prevail.

A prominent feature of the Southern Colonial is a group of columns at the main entrance. These columns are usually two stories in height and support the roof which extends out over the front porch, all lending an imposing dignity to the building. Hand rails, stairtreads, and doors are usually of mahogany, while the rest of the woodwork is white. The large chimney of brick or stone so prominent on the outside of homes indicates generous fireplaces within. Where ornamentation is used either indoors or out, it is generally an adaptation of the classic, except, perhaps, the wreaths and festoons, which are taken from the French or the Adam brothers of England. An outstanding feature of every Colonial building is the entrance doorway. The variety of styles is large. They always have a decided air of refinement, dignity and welcome. The delightful colored photographs by Wallace Nutting which have become nationally known have had a large part in familiarizing the



THE illustration at the right shows a number of designs of "Modern Colonial" builders' hardware. This group of hardware, prepared by W. H. Whittaker, appeared in a recent issue of "The House Beautiful" and shows in detail the excellent modern adaptations of hardware used in Colonial homes

public generally with New England Colonial exteriors and interiors.

It should not be considered that the Colonial type is limited in its adaptability to homes alone. It is used with most pleasing effect in theaters, hotels, the smaller office buildings, schools and churches.

There are two different ways of doing Colonial buildings. One is to make a building in all details as nearly like it would have been built two or three hundred years ago. The other method is to build it with the general Colonial characteristics using modern construction and materials. The first may be called "Old Colonial," and the latter "Modern Colonial."

For the "Old Colonial" iron hinges, latches and bolts, hand wrought and painted black, with bright brass knobs and occasional other small parts, by way of beautiful contrast, is quite the proper hardware to use. A group of this style of hardware taken from the catalog of James Peters & Son, local makers in one of our Colonial centers, gives an extremely good idea of this type. However, there are comparatively only a small number of "Old Colonial" buildings built in these days. The great majority of people want all the "Modern" conveniences and appliances with only the "dress" of the "Old," and it is for these that "Modern Colonial" hardware is made. For the most part the locks and butts and bolts used on "Modern Colonial" buildings are the same mechanically as for other styles of buildings, but the knobs, escutcheons, sash lifts, and other decorative pieces should be selected with an eye to simplicity, dignity and beauty of line.

"Sectional trim"—that is, the knob and rose being separate from the keyhole escutcheon, is very generally used. There are many "Colonial designs" having the elongated rose and escutcheon combined in one plate. They have an advantage because there is a better opportunity to use larger and better placed screws, but they have not the true Colonial spirit of simplicity that is expressed by the sectional trim.

Glass knobs are used quite commonly and are very good looking. They always appear bright and cheerful and do not tarnish. Those octagonal in shape are

used more than any others. Two and a quarter inches in diameter is the standard size, but they look better slightly undersized rather than oversized. There is a growing demand for small brass knobs. As they are not so generally used as the glass, they may be said to be a little more "exclusive." There are several patterns made with the old-fashioned, thin necks so common in Colonial times. This style of knob is rather small, from one and three-quarters to two inches in diameter. It is "good Colonial" to have them small, but they can be too small for comfortable use.

Small keyhole escutcheons with drops over the keyhole are very good. There are a number of patterns reproduced from examples of Old Colonial times. The plain round or oval type without the drop is frequently used, looks well and costs less than those with the drop.

Black iron, or brass rim locks of the horizontal type are sometimes used, but they are more fitting with "Old Colonial" than with the modern type. Horizontal mortise locks, with the keyhole between the knob and the face give a particularly good Colonial effect, but they cost more than the usual upright pattern.

For entrance doors there is a large assortment of brass handles with thumb pieces instead of knobs to operate the lock. These locks have the cylinder rose separate from the handle in true sectional fashion.

A Colonial entrance door is hardly complete without a good brass door knocker, even though there be an unobtrusive electric push button for real use.

In a recent issue of *The House Beautiful* there was shown a group of hardware suitable for use in "Modern Colonial" houses prepared by W. H. Whittaker. The selections are so good and the execution of the drawings is so artistically done that the liberty is taken to reproduce them here.

Brass, either "bright" or "scoured," is the metal that should be used with Colonial architecture. In association with the white and mahogany woodwork the effect is particularly pleasing. Other finishes may be used with very satisfying results, but they are less appropriate.

CHAPTER XIV.

Blueprints and Specifications

THE study of any branch of knowledge is educational and may be interesting. In either case it is quite worth while, but if one expects to turn it into a source of income the application, or "the-how-to-use-it," must be acquired.

In the preceding articles the construction and functions of the items of hardware in most common use, the metals and finishes used and the styles and designs, have all been touched upon. It seems proper that the next step should be the placing of the hardware on a building. To do this one must have a working knowledge of the building, and since "builders' hardware" is usually supplied for new buildings and must be provided before the building is complete, in fact, calculations for supplying it must often be made before the building is started, it is necessary to know something of the plans, or "the blueprints," from which the building is to be built.

An architect draws the plans for a building in pencil, and then inks them in on tracing cloth. As there

will be several copies required, they are printed by a simple photographic process which turns the paper blue with the lines in white, for which reason they are called "blueprints." When plans are printed, as in this article, the paper remains white and the lines are black, but whether blueprints or black and white prints, the object is the same. It is not uncommon for one unaccustomed to using blueprints to approach them with the firm conviction that they "know nothing about such things" and "cannot learn," any more than if it were something printed in some foreign language. They imagine a blueprint is something quite difficult to understand, while in fact it is not.

The blueprints are the patterns for the house. They are made in what is known as the "floor plans," "elevations" and "details." The "floor plans" show the arrangement of the rooms as though you were looking down on them from above, with the location of the doors, windows, light and bell outlets, bathroom fixtures, etc. The "elevations" show the outside of



the house, one side or end at a time, giving the appearance of the doors, windows and all the other features. Sometimes there is one showing the outside of the house as though you were looking at it from an angle, enabling you to see one side and one end at the same time—this is known as a “perspective.”

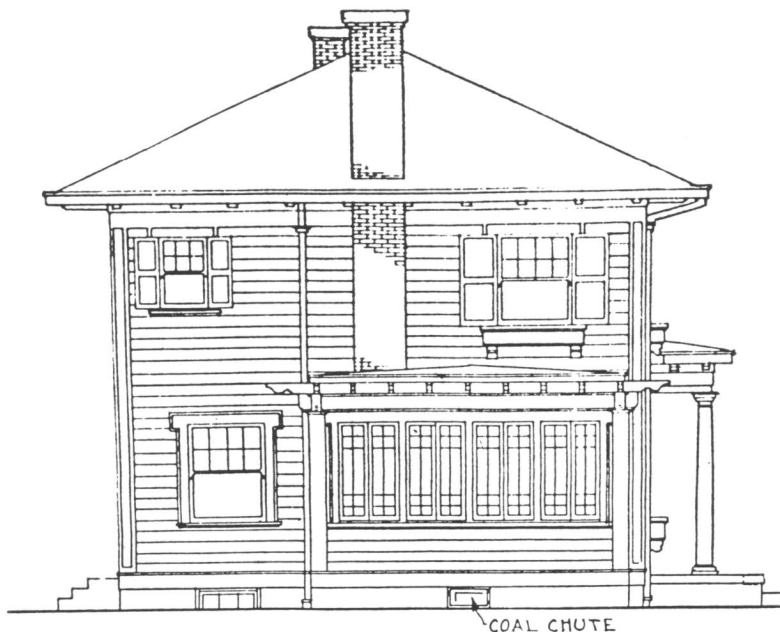
The “floor plans” and “elevation” are usually drawn to a size wherein $\frac{1}{4}$ in. on the blueprint represents 1 ft. on the house, and is said to be drawn to a “quarter inch scale,” and is so marked on the blueprint. All blueprints are not made to a “quarter inch scale,” so it is important to observe carefully what the scale is, sometimes it is “one-eighth inch scale,” and sometimes larger, but whatever it is it should be plainly marked on the blueprints for a guide. In measuring on blueprints a “scale rule,” that is, a rule laid off in $\frac{1}{8}$ in., $\frac{1}{4}$ in., $\frac{1}{2}$ in. and $\frac{3}{4}$ in. spacing, each space representing a foot, should be used. This is

an inexpensive little rule that can be carried in the vest pocket and is very convenient. Measuring on the blueprint with a scale rule is frequently referred to as “scaling the blueprint.” Figures are placed on the blueprints to show the size the finished part is to be in feet and inches. These “figured” sizes are always to be used in preference to “scaling the blueprint,” as they are intended to be accurate; that is why they are put there.

What “The Details” Are

The “details” are larger drawings of certain important parts where it is desirable to show more clearly what is intended. They show the part in elevation, that is, as though you were standing looking at it, and then they show “section drawings” of certain parts. A “section” is as though the part were cut off at the place indicated and you were looking at the end where it was cut off. This is particularly

B*OTH* of these illustrations were used in a recent issue of “The American Builder.” The scale to which they both are drawn is $\frac{1}{4}$ in. to 1 ft. in the original drawings



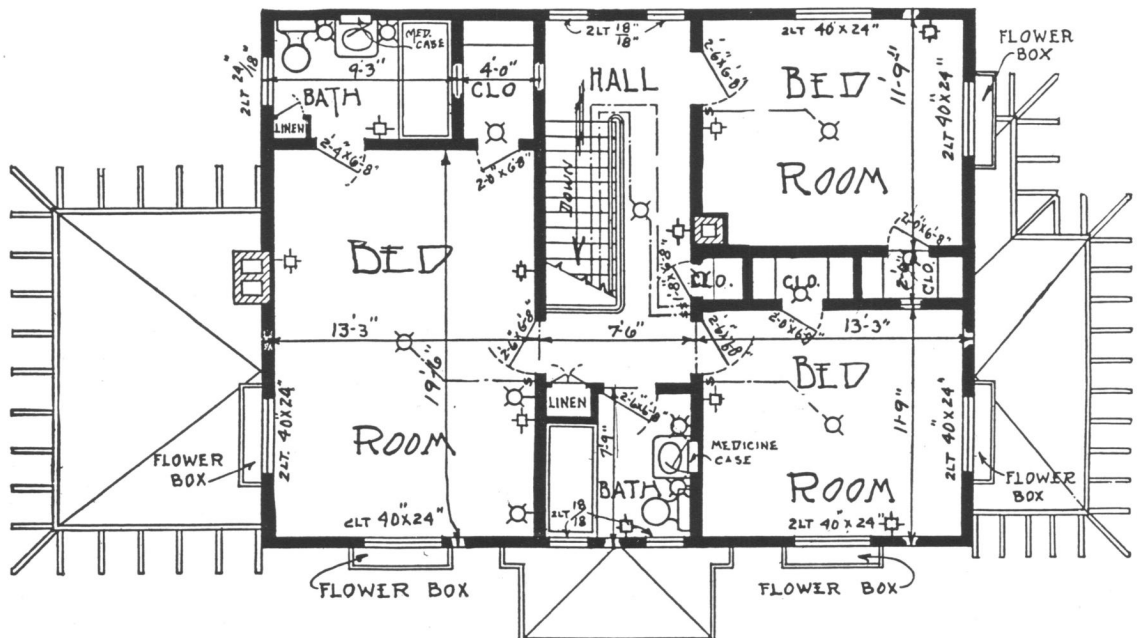
T*HE* illustration at the top of the page shows how the front elevation of a house appears on the blueprint, while that at the right shows the end

important regarding doors and windows to enable one to determine what hardware should be used. From a "section" of a door showing the jamb and casing and trim, one will know the thickness of the door, the width of the stile, whether the face is flat, beveled or rabbeted, and how large a butt is required to allow the door to clear the trim in opening back against the wall. The details are drawn to a larger scale than the floor plans and elevation, 1½ in. or 3 in. to the foot, "half size" and sometimes "full size." It requires a careful study to get the idea of the blueprints, but once you do get it the rest is quite easy

and in a little time one should be able to clearly understand them.

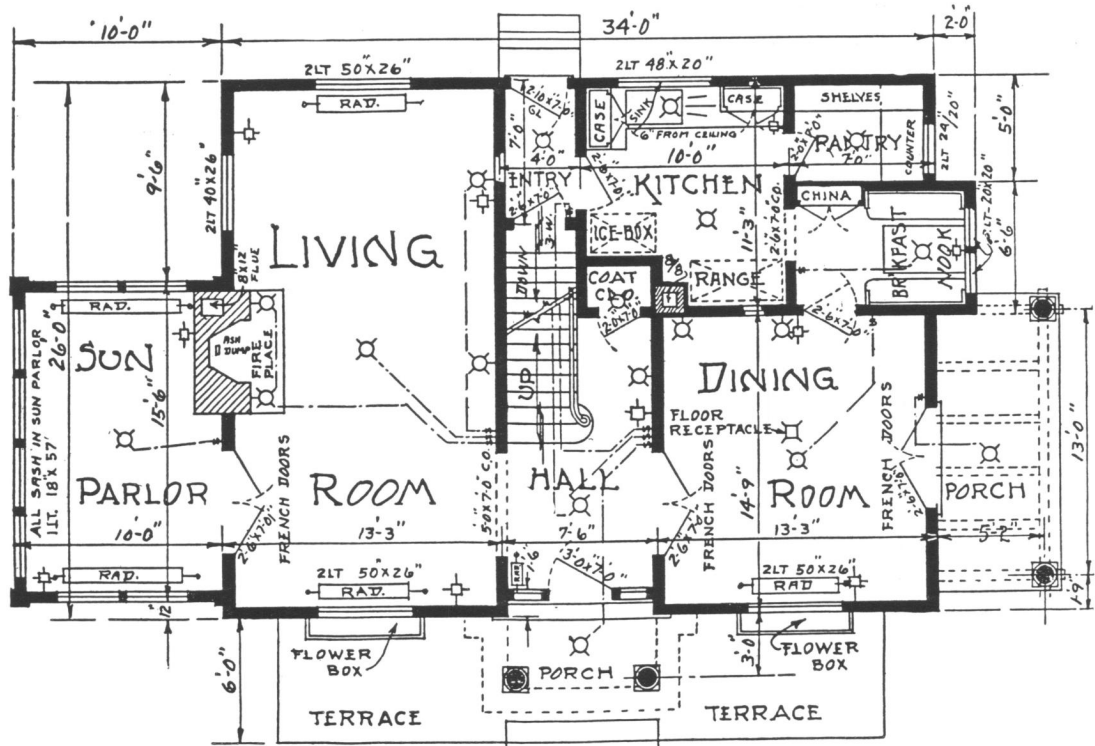
The "Specifications"

To accompany a set of blueprints for a building the architect prepares what is known as a "specifications." This describes or specifies in minute detail all the materials he wants used in building the house and the manner in which they are to be used. In the beginning there is a general clause relating to general conditions which affect alike the general contractor and all the various materials and workmen



SECOND FLOOR PLAN

At the right is shown the way in which the floor plans appear on the blueprint. Plans for the first and second floors are given. These also appeared in "The American Builder." The scale of 1/8 in. to 1 ft. also obtains in the floor plans in the original drawings



FIRST FLOOR PLAN

employed. Then there is a section covering each branch of the work, such as masonry, mill work, carpentry, tin work, painting, hardware, etc., which tells particularly what is expected under each section. The blueprints and specifications should supply all the information necessary to enable a contractor to build a house just as it has been planned and intended by the architect. It will be seen that the specification is of much importance. The general clauses, the "mill work" and "carpentry" as well as the "hardware" sections should be carefully read to be sure to know exactly what is expected of the "builders' hardware man." Sometimes mention is made in "mill work" or "carpentry" of things that are of importance to the hardware man, usually they contain necessary information, and there are times that they contain things that the "hardware man" will want to protect himself against.

Since doing a thing is about the best way to learn how to do it, the plans for a small house are reproduced in connection with this article. They are taken from the *American Builder* of last December. These have been selected as they represent a rather modest dwelling typical of what may be found in almost every town and city and, too, because they have been carefully prepared and can be easily understood. There is a "front elevation," an "end elevation," a "first floor plan," a "second floor plan" and some "details." The elevations and floor plans are drawn to a $\frac{1}{8}$ in. scale, while the "details" are "half size," as shown on the following page. In a complete set of plans for this house there would be a "basement plan," another "end elevation" and a "rear elevation," but the plans shown here will answer the intended purpose.

How to Make a List of Hardware Needed

The thing to do now is from these plans to make up a list of the hardware required to properly equip the house when finished, and to have hardware that will be suitable and will fit, enough for everything and none left over. Take the first floor plan to begin with and make up a list of the doors, windows, etc., after which a list of suitable hardware for them may be made up. It will be seen there is a front entrance door opening to the right, a right-hand door, and that it is 3 ft. wide and 7 ft. high. The front elevation shows there is a small window on either side of the front door, these are called "side lights," and there is a transom sash over the door and each side light. Such side lights and transoms are usually put in stationary unless there is something to show otherwise. There are a pair of French doors between the living room and the sun parlor, a pair of French

doors between the hall and the dining room, and a pair of French doors from the dining room to the porch, all the same size—2 ft. 6 in. wide and 7 ft. high. There is a hall door from the coat closet—2 ft. wide and 7 ft. high; a door between the dining room and pantry 2 ft. 6 in. by 7 ft. (note that this is a "double-acting" door and swings in either direction); a china closet in the breakfast nook with a pair of doors above a counter shelf, and, no doubt, with a pair of doors and two drawers below, although they do not show on the plan. The double dotted line at the opening between the breakfast nook and the kitchen indicates there is to be no door there. There is a kitchen door to pantry 2 ft. by 7 ft.; a kitchen door from the entry 2 ft. 6 in. by 7 ft.; a door entry from the cellar stairs 2 ft. 6 in. by 7 ft.; and an entrance door to the entry 2 ft. 10 in. by 7 ft. Then there are two "cases" in the kitchen each with a pair of doors. These will be cupboard doors, and there probably will be no doors below the sink unless the details should show it. Note that there are no doors showing to the shelves in the pantry, but it is a good plan to look in the "mill work" specifications and in the details to see if there are any shown.

On the second floor plan there are three hall doors to bedrooms each 2 ft. 6 in. by 6 ft. 8 in.; one hall door of the same size to the bath; one bedroom door from the bath 2 ft. 4 in. by 6 ft. 8 in.; three bedroom doors from closets 2 ft. by 6 ft. 8 in.; one hall door from closet 1 ft. 8 in. by 6 ft. 8 in.; one pair of hall doors from the linen closet. The line across this opening indicates this door does not extend to the floor and there may be a drawer under the doors (see "mill work" and "details"); one bathroom door from the linen closet, which is quite narrow but appears to extend to the floor; one medicine closet in each bathroom. In a house of this kind the medicine closets probably have wood doors, with mirrors, although in many houses the medicine closets are of steel and are bought complete and set in.

Now for the windows. In the sun parlor there are eight pairs of casement sash (see front and side elevation). These, no doubt, open out so they will be weather proof. There are three double hung windows in the living room; one in the dining room; two in the breakfast nook; two in pantry and kitchen; six in the bedrooms; three in the baths, and two in the hall. The elevations show all these to be double hung. On the second floor each window has a pair of shutters on the outside—as seen on the "elevations."

All the above "openings" will be made into a list and from this a list of the necessary hardware will be made.

CHAPTER XV.

Estimating the Quantity of Hardware

A NUMBER of the leading hardware makers, working together, have selected and printed a number of "details" to which "standard hardware" can be applied. These "details" conform to those used by most of the best architects. The more they are used the less "special hardware" will be required which will eliminate much unnecessary expense and annoying delays. For our purpose, these "details," printed herewith, will be referred to.

This "schedule of openings" is the result of the preceding article:

First Floor

- (1) 1 Single front entrance door, 3 ft. x 7 ft.—right hand.
- (2) 1 Pair french doors living room from porch, 2 ft. 6 in. x 7 ft.

- (3) 1 Pair french doors hall to dining room, 2 ft. 6 in. x 7 ft.
- (4) 1 Pair french doors dining room from porch, 2 ft. 6 in. x 7 ft.
- (5) 1 Single door hall from coat closet, 2 ft. x 7 ft.
- (6) 1 Double acting door dining room to breakfast nook, 2 ft. 6 in. x 7 ft.
- (7) 2 Pair doors China closet breakfast nook
2 Drawers
- (8) 1 Single door kitchen to pantry, 2 ft. x 7 ft.
- (9) 1 Single door kitchen from entry, 2 ft. 6 in. x 7 ft.
- (10) 1 Single door entry from cellar stairs, 2 ft. 6 in. x 7 ft.
- (11) 1 Single door entrance to entry, 2 ft. 10 in. x 7 ft.
- (12) 2 Pair doors "cases" in kitchen
- (13) 8 Pair casement sash—open out sun parlor
- (14) 3 Double hung windows, living room
- (15) 1 Double hung window, dining room
- (16) 2 Double hung windows, breakfast nook
- (17) 2 Double hung windows, pantry and kitchen

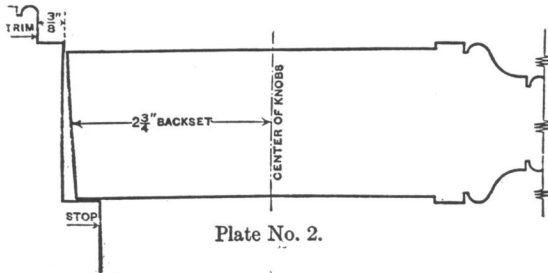


Plate No. 2.
Single Entrance and Vestibule Doors
with Beveled Front,
using Cylinder Lock, Front beveled 1/8 in 2 Inches.
Regular Backset, 2 3/4 Inches.

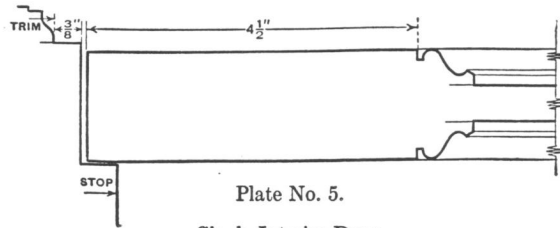


Plate No. 5.
Single Interior Door
with Flat Front, not Beveled,
using Bit Key Lock.

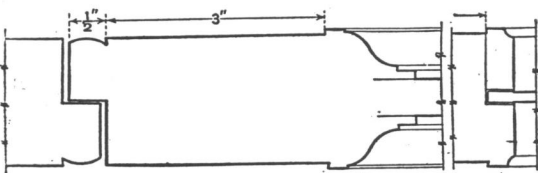


Plate No. 11.
Double Narrow Stile Doors
with Rabbeted Meeting Stiles,

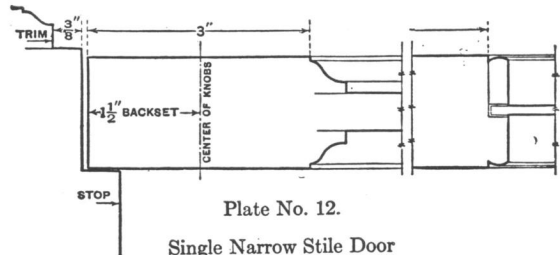


Plate No. 12.
Single Narrow Stile Door
with Flat Front, not Beveled,
using Bit Key Lock.
Regular Backset, 1 1/2 Inches.

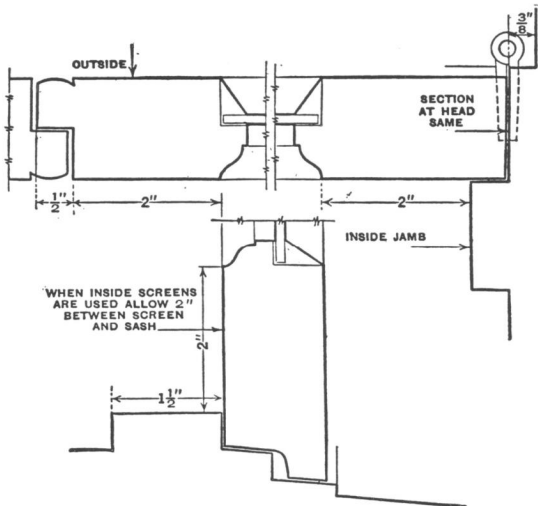


Plate No. 17.
Double Casement Sash, Opening Out,
with Rabbeted Meeting Stiles,
using Rim or Mortise Casement Fastener or Turnbuckle and
Adjusters.

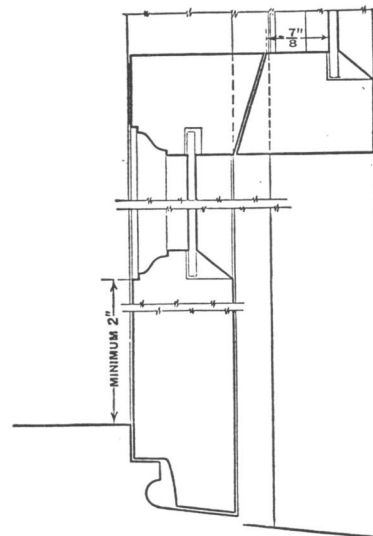


Plate No. 27.
Double Hung Sash,
Bottom Rail and Meeting Rails,
using Sash Lifts and Fasteners.

Details to which standard hardware can be applied

Second Floor

- (18) 3 Doors hall to bed rooms, 2 ft. 6 in. x 6 ft. 8 in.
 (19) 1 Door hall to bath, 2 ft. 6 in. x 6 ft. 8 in.
 (20) 1 Door bed room from bath, 2 ft. 4 in. x 6 ft. 8 in.
 (21) 3 Doors bed room from closet, 2 ft. 4 in. x 6 ft. 8 in.
 (22) 1 Door hall from closet, 1 ft. 8 in. x 6 ft. 8 in.
 (23) 1 Pair doors hall from linen closet
 (24) 1 Single door bath from linen closet
 (25) 2 Single doors bath from medicine closet
 (26) 6 Double hung windows bed room
 (27) 3 Double hung windows in bath
 (28) 2 Double hung windows in hall
 (29) 11 Pair outside shutters

The items of hardware to be used (not the quantities of each item) are usually set forth in the "architect's specification." For the purpose here, however, we will decide that as we consider each opening of the above schedule and prepare a schedule of the quantity of hardware required for this house.

For convenient reference each opening in the schedule has been given a number:

No. 1, Front door. Refer to detail 2 and note this door is 2 in. thick, has the face beveled, has a stile 5 in. wide clear of moulding. This is wide enough to accommodate any suitable cylinder lock and handle. The "trim" is shown as $\frac{3}{8}$ in., but this is only the edge that should be protected by the lock strike (the standard strike will do this). The full thickness of the trim, including the "back-band," we will say, is $1\frac{1}{2}$ in. This will require butts wide enough to clear it, or, as shown in the article printed in the January 10 issue equal to twice the thickness of the door which would be 4 in., plus the thickness of the trim, this makes $5\frac{1}{2}$ in., less $\frac{1}{2}$ -in. for "relish," this leaves 5 in.; so the butts must be 5 in. wide, and 5 in. high, or 5 in. x 5 in. a standard size. It is well to supply three butts, and because it is an outside door it is proper to use fairly heavy brass butts. In addition to the butts, locks and handle, a suitable door knocker may be used to good effect, in which case the electric push button should be small.

Nos. 2, 3, 4 are pairs of french doors; that is, doors with glass to the bottom rail (see detail 11). Note the stiles are only 3 in. wide and $1\frac{3}{4}$ in. thick, which justifies using three butts to each door to prevent them from warping and, following the rule referred to above, must be $4\frac{1}{2}$ in. x $4\frac{1}{2}$ in. The doors have rabbeted fronts, and the right hand door must open first; so the lock must have a $1\frac{1}{2}$ in. backset, a rabbeted face and be right hand. As these doors have narrow stiles, lever handles should be used on the side opening from you to prevent injuring the hand by striking against the edge of the other door. The standing leaf must have a bolt to secure it at the top and bottom when closed.

No. 5 is a narrow door and will have a narrow stile (see detail No. 12). This shows it to be $1\frac{3}{4}$ in. thick with a 3-in. stile which will accommodate a lock having a $1\frac{1}{2}$ -in. backset. Since it is from a coat closet that under ordinary circumstances will not be locked, it would be all right to use a latch with knob outside, but it may have a spindle with thumb piece only for the inside as it is for emergency use only. This door will require three $4\frac{1}{2}$ in. x $4\frac{1}{2}$ in. butts.

No. 6 is a door that swings both ways and should be hung with a set of floor spring hinges and have

a push plate 3 in. x 12 in. on each side. There need be no lock as a door of this kind is seldom required to be locked.

Nos. 7 and 12. These cupboard doors, we will say, are made alike and will be $1\frac{1}{8}$ in. thick. They will require two butts $2\frac{1}{2}$ in. x $2\frac{1}{2}$ in. for each. For one door of each pair an "elbow catch" should be supplied for fastening on the inside and for the other door a "cupboard turn." For each drawer supply one, "bar drawer pull" or sash lift. This will be found more convenient than the regulation "drawer pull."

Nos. 8, 9, 10 and 11. These doors are similar, and according to detail No. 5, are $1\frac{3}{4}$ in. thick with stiles $4\frac{1}{2}$ in. wide—they should each have three butts and a $4\frac{1}{2}$ in. mortise knob lock. The door No. 11 being the one most apt to be tried by a burglar should have in addition a "cylinder rim night latch" for security when the maid is out, and this door as well as door No. 10 may well be supplied with a "barrel bolt." It may be reasonably argued that this is rather an over supply of hardware for these two doors, but as said before, these are the doors most frequently entered by burglars and the extra hardware recommended is a reasonable precaution. Since we are working on the doors suppose we go next to the doors of the second floor before we take up the first floor windows.

No. 18. These doors are made to the same detail (No. 5) as the first floor doors and should have three butts and a $4\frac{1}{4}$ in. mortise knob lock for each.

Nos. 19, 20. These doors are both "bath room doors" and will require the same kind of hardware, but since No. 19 opens into the bath the butts and lock front and strike should be nickel-plated while door No. 20 opens into the bed room and should have the butts, lock face and strike, in the same finish as the hardware in the bed room. For this reason it is a good plan to list them separately. The locks for these doors should have the dead bolt operated by a thumb knob from the bath room side and by a key from the other side in case of an emergency.

No. 21. These are closet doors and it is not uncommon to make them thinner than the room door, so we will say they are $1\frac{3}{8}$ in. thick, but otherwise like detail No. 5. This means they may be hung on butts 4 in. x 4 in., instead of $4\frac{1}{2}$ in. x $4\frac{1}{2}$ in., and that they may be supplied with $3\frac{1}{2}$ in. mortise knob locks, with knob outside and spindle thumb piece inside.

No. 22. This is a narrow door and made like detail No. 12, except that it is only $1\frac{3}{8}$ in. thick. It will require 4 in. x 4 in. butts and a knob lock having a $1\frac{1}{2}$ in. backset.

No. 23. These doors will be $1\frac{1}{8}$ in. thick, but will be taller than ordinary cupboard doors so 3 in. x 3 in. butts should be used, two to each door. One door should have a good elbow catch to hold it when closed, the other should have a $1\frac{1}{2}$ in. backset "half mortise" catch to be operated from the outside only by a knob.

No. 24 is a single door like 23, and should have the same butts and catch.

No. 25. These doors are $\frac{7}{8}$ in. thick, and have stiles 2 in. wide. They should have 2 in. x 2 in. butts and 1 in. backset half mortise catches same as for doors 23 and 24.

No. 13 is a casement sash in sun parlor. As these open out galvanized butts with fast brass pins 3 in. x 3 in. may be used; see detail No. 17, which shows these sash $1\frac{3}{8}$ in. thick. The sash closing first will need a bolt at the top and one at the bottom. Each

sash should have a "casement adjuster" to hold it when open, and there should be one "rim casement fast" for each pair of sash.

Nos. 14, 15, 26, 28. These are all double hung sash (see detail No. 27). These will require twelve "sash fasts" of medium size. The large sash will each need two flush sash lifts, but for the two narrow sash at No. 28, one sash lift each will be enough. Sash pulleys, sash bead, screws and washers, sash cord and sash weights can be taken care of under a heading "miscellaneous."

Nos. 16, 17, 27. Are seven double hung sash, listed separately because the finish will not be the same as the other D H sash. These will require seven sash fasts and as four of these sash are narrow ten flush sash lifts will be enough.

No. 29. Is 11 pair outside shutters. Because the type of hardware used on outside shutters varies so much for different localities, we will not here suggest the type to be used, but leave it to be cared for according to the usage in each locality, but do not fail to estimate hardware for them.

Miscellaneous—Under this heading should be grouped the items not cared for under the "opening." Each sash will require four sash pulleys $2\frac{1}{4}$ inches size; a quantity of iron sash weights, the amount to be estimated according to the rule given in a previous chapter; about 16 ft. of No. 8 good quality braided white cotton sash cord for each window; ten sash bead screws and washers for each window. Each door should be supplied with a rubber tipped "wood door stop" to be painted with the base boards in each room. For each clothes closet and for the coat closet furnish twelve good "coat and hat hooks" and six "ceiling hooks." For each bath room supply two nickel-plated "coat and hat hooks," and if specified (or if the owner will buy) the necessary bath room fixtures such as towel racks, etc.

From the above we have a schedule of hardware as shown below. In actual practice one accustomed to estimating hardware would arrive where we are now in a much less laborious way than that used here, but it seemed advisable for our purpose to obviously cover each step. Experience will suggest "short cuts" for each person.

Opening No. 1

- 1½ pair butts 5 x 5
- 1 set cylinder front door locks and handles
- 1 door knocker
- 1 small push button

Openings 2-3-4

- 9 pair butts $4\frac{1}{2}$ x $4\frac{1}{2}$
- 3 bolts for top
- 3 bolts for bottom
- 3 set locks with knobs and lever handles

Opening 5

- 1½ pair butts $4\frac{1}{2}$ x $4\frac{1}{2}$
- 1 set latches with knob outside and thumb piece inside

Opening 6

- 1 set floor spring hinges
- 2 push plates

Openings 7 and 12

- 8 pair butts $2\frac{1}{2}$ x $2\frac{1}{2}$
- 4 elbow catches
- 4 cupboard turns
- 2 bar drawer pulls

Openings 8-9-10-11

- 6 pair butts $4\frac{1}{2}$ x $4\frac{1}{2}$
- 4 set locks with knobs
- 1 cylinder rim night latch
- 2 barrel bolts 4 in.

Opening 18 (3 doors)

- 4½ pair butts
- 3 set locks with knobs

Opening 19

- 1½ pair nickel plated butts $4\frac{1}{2}$ x $4\frac{1}{2}$
- 1 set bath room locks with knobs

Opening 20

- 1½ pair butts $4\frac{1}{2}$ x $4\frac{1}{2}$
- 1 set bath room locks with knobs

Opening 21

- 4½ pair butts 4 x 4
- 3 set locks with closet spindle

Opening 22

- 1½ pair butts 4 x 4
- 1 set locks—1½ in. backset with closet spindle

Opening 23

- 2 pair butts 3 x 3
- 1 elbow catch
- 1 half mortise catch with knob

Opening 24

- 1 pair butts 3 x 3
- 1 half mortise catch with knob

Opening 25

- 2 pair butts 3 x 3
- 2 half mortise catch with knob

Opening 13—8 pairs casements

- 16 pair butts 3 x 3
- 8 bolts for top
- 8 bolts for bottom
- 8 casement fasts
- 16 casement adjusters

Openings 14-15-26-28

- 12 sash fasts
- 22 flush sash lifts

Openings 16-17-27

- 7 sash fasts
- 10 flush sash lifts

Opening 29—outside shutter

- 11 sets of hinges, etc., complete

Miscellaneous

- 76 sash pulleys $2\frac{1}{4}$ in.
- ? lb. iron sash weights
- 300 ft. sash cord No. 8
- 190 sash bead screws and washers
- 22 door stops
- 60 coat and hat hooks
- 30 ceiling hooks
- 4 coat and hat hooks for baths
- ? bath room fixtures

CHAPTER XVI.

Selecting Hardware for the House

THE selection of appropriate hardware for any building is a matter deserving careful consideration for the pleasure and contentment of the user of the building will be affected by the result of the choice. In a successfully made selection the elements of *suitability*, *durability* and *simplicity* must each receive a considerable share of study for these are the three important points in any selection, be it clothes, an automobile, a home, hardware or anything else. If these three points are really satisfied the selection will be a success. Suppose we think of each of these in turn.

Suitable hardware must be particularly well adapted to the purpose for which it is to be used. Hardware suitable for a small cottage would be quite out of place on a large and expensive dwelling. Hardware suitable for a factory building would not be proper to use on a church. Hardware suitable for a hotel would not fill the requirements for an office building, and we might continue, but this will be enough to illustrate the point. The various types of buildings are designed to be used in different ways, and the way the building is to be used very much affects the selection of hardware that will be *suitable*.

While the functions required of the hardware for a small cottage are the same as those for the more elaborate dwelling, it would be quite out of place to have the quality the same. It would be proper to make the choice for the cottage from the less expensive kinds but for the better building the hardware should be of quality equal to the other materials used, or it would not be in harmony with its surroundings. One has a right to expect to find high quality hardware in company with plate glass windows, hardwood floors and mahogany doors.

For a factory building the hardware should be strong and durable, but the material of which it is made and the finish need not be expensive. Service should be the main consideration.

For a church the design and finish of the hardware are important and should be in harmony with the building.

The office building and the hotel are usually well built of high-grade materials so the hardware should be well made of first-class materials. In such buildings one expects to find cylinder locks with functions well adapted to the use of the building, bronze metal butts, bolts and window hardware of a quality and weight that will stand the wear that it will surely get.

Most buildings are expected to render their service for many years, and most of them do. As hardware is an important part of the building it, too, should faithfully render its service in keeping with the other materials used. To do this the factor of durability must be given its due share of consideration when the selection is being made. Cheap flimsy goods of any kind are usually expensive and unsatisfactory at any price.

Simplicity in hardware, as in other things, is one of the principal marks of good taste. It has a service to perform and should not be made an object of too much display. It should be a permanent expression of the good taste and good judgment of the owner of the building. Of course, hardware will show, but the show should be of a satisfying sort—a show that

compels admiration for its fitness, rather than attract attention by much display. In fact, doors are not made for display boards. Hardware is intended for a useful purpose, and should be convenient, strong, well proportioned, not too conspicuous, and the most efficient for the purpose.

It cannot be too strongly urged to make the selections from goods of standard make, goods that have earned a reputation for quality. Keep away from specially designed devices as much as possible, there are enough kinds of hardware regularly made to meet most requirements. Special pattern work is expensive and the result is not always satisfactory. Locks designed with special functions for particular jobs are much more apt to give trouble than those that are regularly made and have been proved satisfactory.

Again, it is better to use hardware of one maker on a job—the chance for harmony of design and finish is much better than if goods of several makers are hashed together.

With the discussion of the several items of hardware in the preceding articles and with the above general remarks regarding selection, it will be in keeping to take up in detail the selection of suitable hardware for the small house, the plans of which were considered in the two preceding articles.

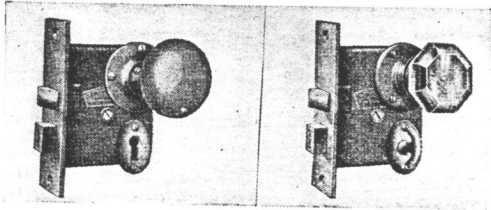
This house is designed along simple Colonial lines and should have plain hardware, in plain natural brass or dull brass finish.

For opening number 1—front door—a sectional handle (205) with a cylinder front door lock having stops in the face and operated from the inside by a knob to match the other interior knobs. A plain knocker (206) for the center of the door, with a push button having a very small plate would, with the butts, complete the trim.

The French windows (2, 3, 4) may be furnished with brass butts of lighter weight than those for the front door because these doors will not be used so much. The locks may be of the mortise, bit key, narrow stile kind—1½ inches to center, and should be of medium weight. The knob should match the other interior knobs and the lever handle mentioned should be of simple design with oval roses and the key hole escutcheon may be oval (207) as will be the thumb knob plate for the inside of the front door (208). These doors may have surface top and bottom bolts (209) for the standing leaf. For the outside door—number 2—additional similar bolts for the top and bottom of the lock leaf gives added security for the night or when the house is not occupied.

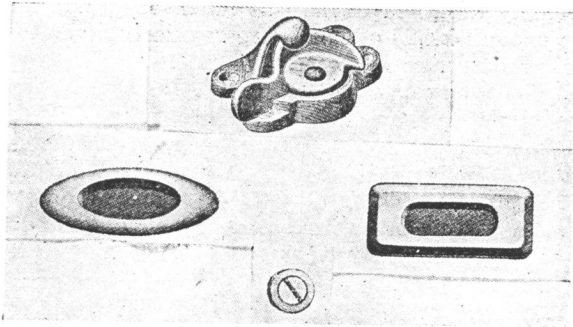
Door number 5, from the coat closet, should have a knob on the hall side to match the other knobs. For this house suppose we use small plain brass knobs about two inches in diameter. Glass knobs are very commonly used in Colonial houses, and look very well, but because of their very common use it is rather good to sometimes use something else, and as long as the small brass knobs are “good Colonial” we will suggest them here in combination with oval key hole escutcheons (210).

For the double acting door, number 6, there should be, in addition to the floor spring hinges, a glass push plate about 3x12 inches for each side. The glass is

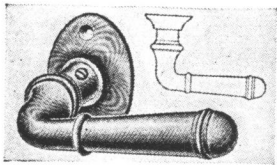


(210) Inside door set with brass knob
(212) Bathroom door set with glass knob

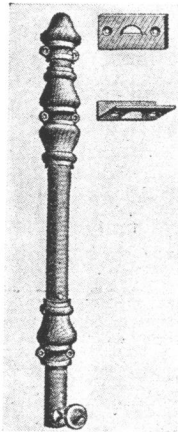
Interior locks, knobs and escutcheons



(213) Hardware for double hung windows



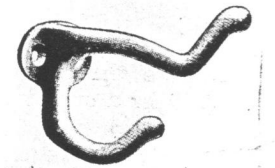
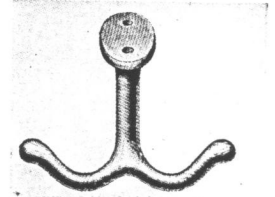
(207)



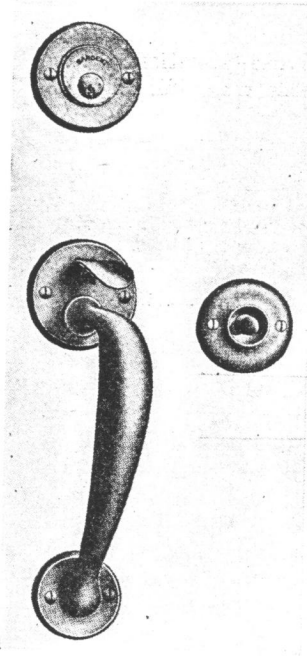
(209)

Hardware for French windows

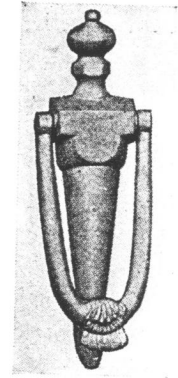
At right—Hooks for closets and bath



(215)

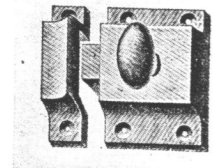
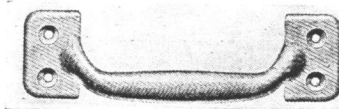


(205)



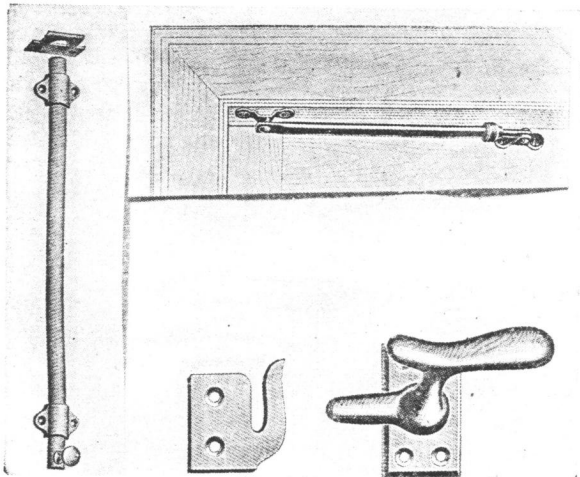
(206)

Hardware for front door

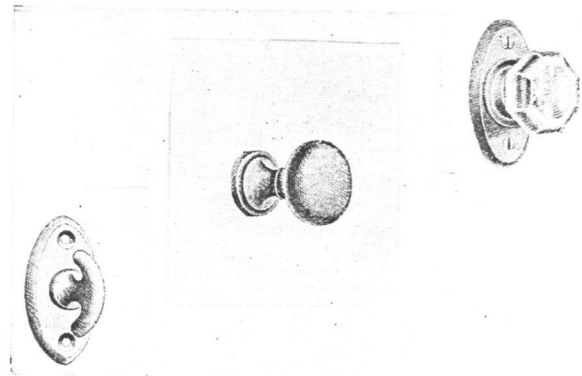


(211)

Breakfast nook and kitchen dresser turns and drawer pulls



(214) Hardware for the casement sash



(208)

(216)

Small knobs for inside front door

better than metal ones as they are more easily kept clean.

The kitchen, breakfast nook, pantry and entry, will probably be painted white and for such rooms it is well to have all the hardware nickel plated on brass—it would not wear satisfactorily if on steel—and with knobs of white porcelain with round roses and round cornered key hole escutcheons will give a very pleasing effect and at the same time show a decided difference from the living portion of the house. For the outside of door number 11, it would be better to use a brass knob rather than one of porcelain, and this knob, rose and escutcheon, may well be of polished brass instead of nickle plated.

The hardware for the cupboards, numbers 7 and 12, was covered in the list (211) except to mention that it, too, should be of brass nickle plated to match the other kitchen hardware.

The doors to the bedrooms on the second floor, number 18, should have good four and one-quarter inch, three tumbler, mortise locks with knobs, roses, and escutcheons to match those in the living rooms of the first floor.

The closet doors, number 21, being thinner than the bedroom doors, may well have a lighter lock, with knobs and escutcheons to match the others.

The room side of the bath room doors, numbers 19 and 20, must match the rooms, but the bath room side may have a glass knob, rose and thumb knob, all the metal parts nickel plated (212). In bath and toilet rooms, generally, it is better to use glass knobs than metal knobs because there is usually considerable dampness and the glass will stand up under such conditions, at the same time having a particularly attractive appearance in company with the room fixtures.

Number 22 should have the knobs, rose and escutcheon on the hall side like the other closet doors. The lock must have a narrow backset on account of the narrow stile.

Doors 23-24-25 should have similar locks as described, but for number 25, the knobs should be of glass, while 23 and 24 should have metal knobs, all these knobs should be of small size, say about one and one-quarter inches in diameter (216).

The double hung windows throughout should have medium sized sash fasts of brass or nickle plate and the flush sash lifts may be of oval design to match the escutcheon, except for the kitchen portion, where they should be of a round cornered design to match the escutcheons in these rooms (213) and of course in the same finish. The pulleys for the double hung sash should be of good quality, and if it can be afforded may have brass faces, however, here is a good place to use economy without sacrificing utility, as pulleys with polished iron faces can be secured that are otherwise as good as the brass face pulleys, and they will not cost as much. However, do not use small, poorly made cheap pulleys as they will not prove satisfactory. For what is more annoying than a window that does not operate easily? The sash bead screws and washers may be very simple but should be of brass.

The casement sash, number 13, should have light slide bolts at the top and bottom of at least one leaf, and a casement fast (214) for the other leaf. The adjusters may be of the friction type that stay and hold the sash in any position it is put.

The hooks for the closets (215) should be strong and in the interest of economy may be of iron, brass plated, but those used in the baths should be of brass nickel plated; also for the same reason, economy, the interior butts, except those in the bath room, may be of iron or steel, plated to match the other hardware. This is not recommended as the best, but simply suggested as a reasonable means of keeping the price down, having in mind that this is a rather small house and it may be necessary to economize where it can be done with reason.

CHAPTER XVII.

Builders' Hardware From the Sales Angle

AND now, the next thing is to sell the hardware we have been talking about. Since selling or bartering is as old as the human race, even as Esau sold his birth-right for bread and pottage—and many another has done the same thing since—and as whole libraries have been written giving the last word on selling by many of the highest of high-powered salesmen, it would be presuming too much to imagine anything new could be told here. Still there are a few things that may be repeated without fear of bad effect.

The type of people who buy Builder's Hardware, owners, architects and builders—are people with some degree of means, taste, and refinement, and to sell them successfully one should be able to understand their building and living problems so that he may reasonably assist them in their choice as to materials, finish, mechanical functions, and harmony of design. The young man to do this should strive for proper personal equipment.

It is pleasant to assume that he has been endowed by Nature with good health and an average degree of

intelligence. That is about as much as one should expect of Nature. With this good start suppose he has been fortunate enough to acquire at least a fair education. Schooling is not imperative. Many men without much schooling have attained a very high degree of real success, but before they had reached the height of their success they had very likely acquired, by experience, observation and reading, a very good education. Many a young man has been unable to survive the exposure to a college education. But, everything else being equal, one should be better equipped for a start with a good amount of schooling—which should mean also a good amount of education, but one not being fortunate enough to receive the schooling may still acquire the education, by observation, reading and experience.

The First Impression

Of course, the young man is particular about his personal appearance. If he isn't he should be. Personal appearance has much to do with first impressions, and first impressions often play an important

part in final results. It is scarcely necessary to say that a prospective customer's mind should not have opportunity to busy itself, wondering when the salesman had last been shaved, or who wore his collar before he did, or when did he wash his hands and clean his nails? It is not expected nor desirable that a salesman should be on "dress parade." But cleanliness and neatness have an appeal to people of refinement.

Salesmanship should not be construed as the art of "putting over" something on a customer. It may be considered as the art of learning by contact the customer's requirements, from an economic and artistic point of view, presenting the goods in a way to bring the customer to the same view point, and then give him a chance to *buy them*—this is selling. The goods will stay sold and bring more customers. Learn as early as possible what kind of hardware the customer wants or should have and then show him that kind.

Avoid Distraction

Do not distract his attention by too large a display or by displaying goods the customer should not at that time be interested in. Keep his mind on the things he should buy. Study the customer's personality—and give him credit for knowing what he wants until he demonstrates by word or action that he doesn't know—then be ready to give reasonable advice as needed in an unobtrusive way—always allowing the customer to feel he has made all the important selections himself. He will like the result better.

It is very proper to tell and to demonstrate the good qualities of your goods, but never make your claims so extravagant that you could not believe them yourself. Your customer probably has as much common sense as you have and is no more likely to accept gracefully unreasonable statements than you are.

Let Him Buy

Do not do too much "selling"—or, rather, do not "over sell" your customer—give him an opportunity to do some "buying"—and there is a big difference from several angles between "selling" a person or letting him "buy." A story is told of a young man raised in the staid New England atmosphere who, last fall, made a business trip to Chicago. While there it turned quite cold and it was necessary for him to get a heavy overcoat. He returned to his family with this coat of unusually boisterous pattern. It was rather a shock to their quiet taste and they asked him how he ever came to buy a coat like that. His answer was, "I didn't buy it, they sold it to me." Study the customer and try to know when he is "sold" or when he is ready "to buy," and try to end the transaction at that point. Some salesmen, having no "terminal facilities," often fail to land the order because they do not recognize the important moment for "closing the sale."

A customer may think he wants "cheap goods"—very well—show them to him, but do not fail to give him a chance to see, and to admire, and perhaps to desire better goods. It is good quality hardware, well suited to its purpose, that should be sold. The profit is better—and the customer will be more satisfied.

Know Your Goods

"Know your goods" should ever be in a salesman's mind. A customer has a right to expect you to know more about hardware than he does. It is your business while it is only an incident in his life. To know your goods requires constant watchfulness and study. You should know why one article is better adapted to a certain purpose than another, and why one article

should properly be higher priced than another and wherein it is better. If you do not know you cannot tell your customer, and it is reasonable that he should wish to know. It will take a reasonable answer to satisfy him. It is by "knowing your goods" and the other details of your business that you gain the confidence of your customers, and unless you can command their confidence and their respect you will not be a successful salesman.

Let the customer *discover* that you "know your goods" rather than *tell* him. Just let the fact "leak out," as it were. One never likes a salesman who is too insistent with his advice or makes too much display of what he knows. A customer may assume to know all about hardware—perhaps he does, and perhaps he doesn't. You will soon discover and will be able to lend your assistance unobtrusively when the proper time comes. Know your business so well that your advice is valuable—your customer will soon recognize this and seek your advice.

Do not handicap yourself with the idea that *price* is the main factor in making a sale. There are so many other elements to be considered that price frequently becomes incidental. If price were the *main factor* everybody would buy jappanned thumb latches, to secure the lowest price.

Restrict Your Lines

Builder's Hardware is usually best sold by carrying a stock made as nearly as possible by one manufacturer. The advantage in matching parts and finishes is obvious. Your buying account would be of much more interest to one manufacturer than it would if divided among several makers.

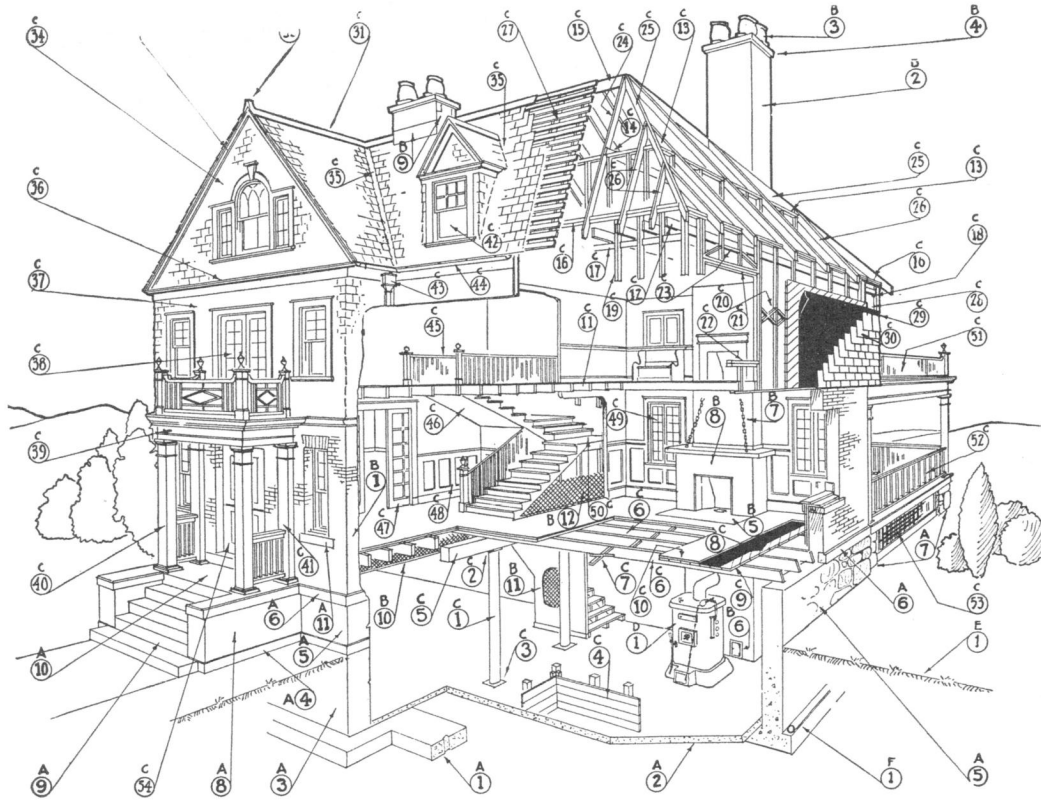
If the line of goods you are selling is of a make that is generally well known because the maker advertises, you will get the benefit of the good will thus produced. This makes the selling problem easier, and makes possible a more satisfactory profit. Most people are willing to pay a reasonable price for hardware of known good quality. This good quality becomes a generally accepted fact through continued advertising by the maker in high class periodicals. In selecting the line of hardware to be sold be sure it is widely and well known, that the maker has a reputation for fair dealing.

Carry a good stock and as far as practicable, sell from your stock—and as much as possible do the selling yourself—rather than depend upon the representative of the maker to do a large part of the work. If he does this, he should be entitled to a part of your profit.

Sell "regular goods." Standard lines furnish an assortment sufficient to meet most requirements. There may be times when it is quite proper to use special design Knobs, Escutcheons, etc.; but always bear in mind that the creator of the building is also the creator of the necessity for the special goods, and it is entirely right and proper that he should willingly pay the entire expense—with a profit to you.

The Architect's Hardware Problem

If you "know your business," you should be able to render very valuable assistance to the architects in your city when they have hardware problems to consider. These gentlemen carry rather heavy burdens because they require expert knowledge regarding many branches of trade. It is quite reasonable to expect they would be glad to avail themselves of your knowledge of Builder's Hardware. They are usually men of culture and refinement and you will likely find pleasure



Reproduced through courtesy of Copper and Brass Research Association.

Commonly Used Terms in Residence Construction

Stone Mason's Work

- A— 1—Footings
- 2—Cellar Floor
- 3—Foundation Wall
- 4—Ground Course
- 5—Underpinning
- 6—Water Table
- 7—Piers
- 8—Buttress
- 9—Steps
- 10—Platform
- 11—Outside Sill

Brick Work and Plastering

- B— 1—First Story Wall
- 2—Chimney
- 3—Chimney Pots
- 4—Chimney Cap
- 5—Hearth
- 6—Cleanout Door
- 8—Fireplace
- 9—Chimney Flashings
- 10—Metal Lath and Plaster Ceiling
- 11—Metal Lath and Plaster Partition
- 12—Metal Lath

Carpenter Work

- C— 1—Iron Columns
- 2—Column Cap
- 3—Column Base
- 4—Coal Bin
- 5—Girder

Carpenter Work (Cont.)

- C— 6—First Floor Beams
- 7—Double Row Herring Bone Cross Bridging
- 8—Flooring Paper
- 9—Under (or Rough) Floor
- 10—Top (or Finish) Floor
- 11—Second Floor Beams
- 12—Ceiling Beams (or Attic Floor Beams)
- 13—Purlin
- 14—Collar Beams
- 15—Ridge Rafter
- 16—Plate
- 17—Ledger Board
- 18—Corner Post
- 19—Studding
- 20—Bridging
- 21—Rough Head
- 22—Rough Sill
- 23—Truss over opening
- 24—Rafter
- 25—Hip Rafter
- 26—Jack Rafters
- 27—Shingle Lath
- 28—Diagonal Sheathing
- 29—Sheathing Paper
- 30—Shingle
- 31—Ridge Board
- 32—Finial

Carpenter Work (Cont.)

- C—33—Rake Cornice
 - 34—Gable End
 - 35—Valley
 - 36—Eaves Cornice
 - 37—Second Story Wall
 - 38—French Window
 - 39—Porch Cornice
 - 40—Porch Column
 - 41—Pilaster
 - 42—Dormer Window
 - 43—Leader Head and Leader (or Downspout)
 - 44—Gutter
 - 45—Balustrade
 - 46—Stair Soffit
 - 47—Sliding Doors
 - 48—Wainscoting
 - 49—Casement Window
 - 50—Platform
 - 51—Deck Roof (Balcony)
 - 52—Veranda Balustrade
 - 53—Lattice
 - 54—Dutch Door
- D—1—Boiler
 - E—1—Grade
 - F—1—Drain